

GLASS MAGAZINE®

THE GLASS AND GLAZING AUTHORITY

GLASSMAGAZINE.COM

Welcome to the digital edition of Glass Magazine!

To view the issue in a two-page format,
click the triple dots in the upper right corner
and select “Two-page view.”

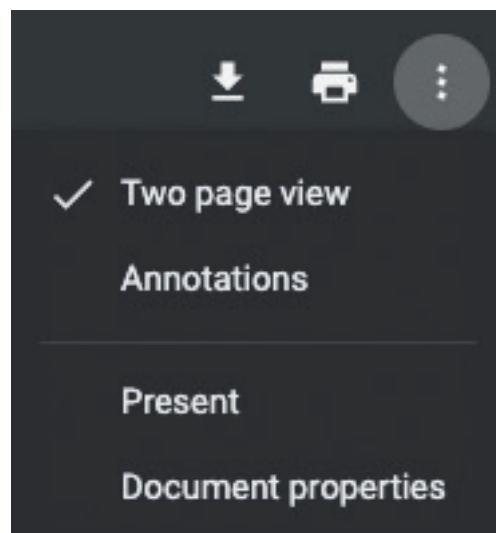

ADVERTISEMENT

G L A S S

M A G A Z I N E

THE GLASS AND GLAZING AUTHORITY • AUGUST/SEPTEMBER 2023

GLASSMAGAZINE.COM

GET GREEN.
GO GREEN.

INNERGY[®] AP
ARCHITECTURAL PRODUCTS



Custom designed Innergy[®] AP Pressure Plates outperform other options to produce a far stronger and more energy efficient curtainwall solution. Scan here for more details.



deceuninck
innergy-ap.com

Superior Thermal Performance without Sacrificing Strength

Custom manufactured to your curtainwall system's specification, Innergy[®] AP products made from Rovex[®] fiber-reinforced polymer, provide outstanding thermal performance but with unprecedented strength.

MATERIAL PERFORMANCE COMPARISON

MATERIAL	ATTRIBUTE					
	Stiffness Flexural Modulus (Mpsi)	Specific Gravity	Density (lbs/in ³)	Stiffness to Weight (FM/SG)	Thermal Coefficient of Expansion (μin/in-°F)	Thermal Conductivity (BTU-in/hr-ft ² -°F)
ROVEX [®] /INNERGY [®] AP	7.5	2.10	0.076	3.6	3.4	1.522
Aluminum	10.0	2.72	0.098	3.7	13	1109.357
Polyamide-6.6 Fiberglass	0.7	1.3	0.047	0.5	11-17	1.596
Polyester Fiberglass	1.6-3.5	1.84-2.00	0.066-0.072	1.8	3-11	2-5

Technical data for materials other than Rovex[®] are provided for reference only. Although every effort has been made to ensure that the information is correct, no warranty is given as to its completeness or accuracy.



DIVE DEEPER INTO **INNERGY AP** PRODUCTS FOR YOUR CURTAINWALL SYSTEM.

innergy-ap.com

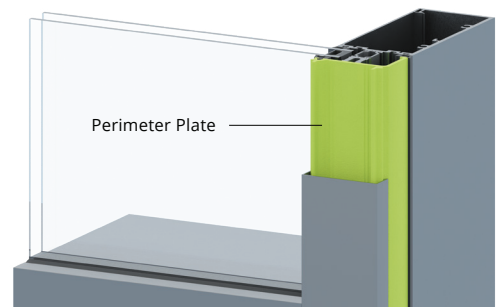

GLASS

MAGAZINE®

THE GLASS AND GLAZING AUTHORITY • AUGUST/SEPTEMBER 2023

GLASSMAGAZINE.COM

2023
GLASS MAGAZINE
AWARDS

A MULTIFUNCTIONAL MARVEL

ALL ABOUT
MIRRORS

BETTER BUILDING
THROUGH BIM

DEMYSTIFYING
HEAT SAFETY

OFFICIAL
PUBLICATION

NGA
NATIONAL GLASS ASSOCIATION OF CANADA

GLASS.ORG

WE NEVER WANT TO BE
JUST A VENDOR.
WE WANT TO BE
A PARTNER.



ERDMAN® HIGH SPEED IG LINE WITH ROBOTIC UNLOAD



Erdman is your local partner in robotics and automation. We will work with you to innovate and reduce your labor requirements to provide a safer environment at your facility as well as a significant cost savings.

Erdman is unique in that we focus on all facets of window manufacturing and can help you integrate your departments and create a safer, more efficient flow through automation.

For 30 years we have concentrated completely on the North American market. We started small, service focused, nimble and innovative. We continue that focus today even as we are big enough to handle the largest of projects.

Visit www.erdmanautomation.com or call 763-389-9475 for more information.

VISIONARY THINKING. EXCEPTIONAL DOING.

ERDMAN 



PLUG INTO THE ULTIMATE TINTING SOLUTION.

VIRACON PLUS AND HALIO | A PARTNERSHIP IN INNOVATION

That's new Viracon PLUS[™] Smart Glass powered by Halio[®], an innovative, state-of-the-art, self-tinting glass solution that makes buildings better for its owners, occupants and the environment.





FEATURES

44. Reflections on Mirror

Answers to top glass industry questions on flat glass mirror

FROM NGA TECHNICAL SERVICES

48. Glass Magazine Awards

See the projects and products that push performance, creativity and innovation to the next level

BY NORAH DICK

INSIGHTS

26. Innovation

Sowing the Seeds of Innovation

BY JIM NIXON

30. Technology

Maximize Efficiency with Software

BY MARK SUEHIRO

34. Safety

Glass Manufacturing Heat Safety

BY M.B. SUTHERLAND

38. Factory Floor

A Checklist for Glass Printing

BY ADAM MITCHELL

DEPARTMENTS

8. Editor's Notes

10. From the NGA

11. Glass Informational Bulletin

16. News to Know

43. Great Glazing: Pulp Studio

72. Q&A: CRL

74. Product Solution: Roto North America

75. Industry Products

78. Suppliers Guide

92. Reader Response Center

94. Here's an Idea

ON THE COVER: The new 43-story skyscraper, 1550 Alberni Street, is this year's winner of the Glass Magazine Award for Project of the Year as well as Best Feat of Engineering. Complex glazing systems were supplied by nominating companies Kuraray and Glass 3 Enterprises, who will share the awards for their work on the project.



GLASSFAB
TEMPERING SERVICES, INC.

“Raise Your Glass With Excellence”

ONLINE

AT GLASSMAGAZINE.COM

 | [YOUTUBE.COM/GLASSMAGAZINE](https://www.youtube.com/glassmagazine)

 | [TWITTER.COM/GLASSMAG](https://twitter.com/glassmag)

 | [INSTAGRAM.COM/GLASSMAGAZINENGA](https://www.instagram.com/glassmagazinenga)

 | [FACEBOOK.COM/GLASSMAGAZINENGA](https://www.facebook.com/glassmagazinenga)

Glass Magazine Weekly newsletter and digital edition: Subscriptions available under the “Subscription Services” tab on GlassMagazine.com



BONUS CONTENT

Available at GlassMagazine.com and glass.org.

RESOURCE

New technical paper examines primary sealant testing in IGUs

REPORT

Glaziers climb a steep road to recovery in new report

TRENDS

Webinar spotlights trends driving glass product development

GLASSBLOG



ISSUES

Supporting School Security

By Lisa May, Wausau Window and Wall Systems



SYSTEMS

Finished Flat Sheet Aluminum

By Tammy Schroeder, Linetec



ADVOCACY

The Conversation on Glass

By Katy Devlin, NGA



PROJECT SHOWCASE

Pictured: Kingspan Light + Air’s UniQuad wall systems, Quadwall translucent skylights and Briteway canopies were integrated on the interior and exterior of Grover Cleveland Charter High School in Los Angeles. Engineered for long-term durability and customization, the translucent walls and skylights feature removable skin technology,

and provide effective daylighting throughout the campus. With removable skin technology, individual exterior or interior panels can be removed and replaced without disturbing the surrounding panels or structure—making maintenance and replacement easier. Photo by Benny Chan/Fotoworks.

Glass Magazine® [ISSN 0747-4261], Volume 73, Number 6, is published eight times annually in January/February, March, April, May/June, July, August/September, October and November/December by the National Glass Association, 344 Maple Ave. West, Unit 272, Vienna, VA 22180; 703/442-4890. There is no charge for subscriptions to qualified requestors in the United States. All other subscriptions will be charged \$49.95 in the U.S., and \$79.95 outside the U.S. Periodicals postage paid at Vienna, Va., and other mailing offices. POSTMASTER: Send changes of address to Glass Magazine®, Subscriptions, Box 460, Congers, NY 10920. Canada Post: Publications Mail Agreement #40612608. Canada Returns to be sent to Bleuchip International, P.O. Box 25542, London, ON N6C 6B2. For all subscription inquiries, please call 1-800-765-7514. ©2023 National Glass Association. All Rights Reserved. Printed in the U.S.A.

GLASS MAGAZINE

Published by the

NGA NATIONAL
GLASS ASSOCIATION
with GANA

344 Maple Ave. West, Unit 272
Vienna, VA 22180
P: 703/442-4890

EDITORIAL

Content Director

Katy Devlin • kdevlin@glass.org

Managing Editor
Tara Lukasik

Senior Editor
Norah Dick

Assistant Editor & Researcher
Rachel Vitello

Creative Lead
Cory Thacker

Associate Director,
Comm. & Digital Media
Bethany Stough

Digital Media Coordinator
Wendy Vardaman

Production Director
Beth Moorman

Circulation Manager
Jo Ann Binz
jbinz@glass.org

ADVERTISING

Publisher

Emily Thompson • ethompson@glass.org
703/442-4890 ext. 150

Senior Sales Consultant

Chris Hodges • chodges@glass.org
703/442-4890 ext. 131 • Cell: 410/459-8619

Sales Consultant

Tristan Scofield • tscofield@glass.org
703/442-4890 ext. 194

Suppliers Guide Sales

Tim O’Connell • toconnell@glass.org
703/442-4890 ext. 129

Sales Coordinator

Cameron Woodell • cwoodell@glass.org

NGA BOARD OF DIRECTORS (2022-23)

Chair
Brian Hale
Hale Glass Inc.

Chair-Elect
Ron Crowl
FeneTech Inc.

Treasurer
Rick Locke
Montana Sash & Door

Immediate Past Chair
Guy Selinske
American Glass & Mirror Inc.

Denise Baker
Spring Glass & Mirror

Silas Koonse
Koonse Glass Co.

Syndi Sim
DFI Diamon-Fusion Intl.

Tara Brummet
Vitrum Industries

Courtney Little
Ace Glass

Jim Stathopoulos
Ajay Glass Co.

Tim Kelley
TriStar Glass Inc.

Jodi Martinez
AllStar Glass Co. Inc.

Kyle Sword
Pilkington

President & CEO
National Glass Association
Nicole Harris

MACHINES THAT

MAXIMIZE



Expand your lineup's capabilities with industry-leading insulating technology.

Upgrade your portfolio with powerful IGis equipment offered by HHH Equipment Resources. Quickly achieve high-quality insulating results with impressive processing times, durable construction and time-tested global performance. Benefit from a patented automation process designed to effortlessly boost productivity and minimize downtime.



Scan to browse
IGis Equipment

Discover HHH's full IGis line, including:

- Automatic Insulating Glass Production Line
- Edge Deletion
- Automatic Spacer Bender
- Vertical Washer
- And more

**THE DIFFERENCE
IS CLEAR.**



hhhglassequipment.com | 724-212-3746

A division of **Salem Fabrication Technologies Group, Inc.**



Elevating a New Generation of Girls in Glass



KATY DEVLIN
Content Director
Editor-in-Chief
kdevlin@glass.org



Watch a video of Camp NAWIC's glass-cutting day.

- Learn more about Camp NAWIC at futureconstructionleaders.org/camp-nawic-san-diego
- Read about NGA's workforce development efforts at glass.org

In June, 70 teenage girls gathered in San Diego, California, to learn about cutting glass and opportunities in the glass and glazing trade. The event was part of Camp NAWIC, from the San Diego National Association of Women in Construction chapter. The free, weeklong program offers a hands-on approach to a construction career to high school girls, and this year marked the first time that glass and glazing were included in the program.

The event was made possible largely thanks to the efforts of San Diego NAWIC board member Kristie Rehberger, general manager, A Glasco Inc. “When I joined the board, I said I wanted to bring in more education about glass. I love the hands-on [events],” says Rehberger. Rehberger teamed up with Linda Young, who runs Camp NAWIC, to bring glass and glazing education to the students through the glass-cutting workshop.

“It was awesome to see the enthusiasm,” says Rehberger. “When the event started, [the campers] came rushing in and were keen to get to work. I was surprised by their eagerness to learn and try something new.”

Rehberger and a team of glass industry volunteers worked with the campers to safely seam and cut glass. The other volunteers included five members

of the A Glasco team, Andrew Haring of the National Glass Association, Christy Sellers of Lemon Grove Glass & Supply and Casey Weir of Roundtree Glass Co.

Bringing women to the trades

NAWIC's—and Camp NAWIC's—mission is to promote career growth and development for women in construction, as women continue to be vastly underrepresented in construction. Women account for just 10.9% of the entire U.S. construction workforce, according to 2022 data from the U.S. Bureau of Labor Statistics.

“The end goal [is] to encourage more young people to choose a career in skilled trades by providing hands-on experience and training that exposes them to promising occupations and incredibly viable career paths in construction—and also debunking misnomers and stigmas surrounding women in the glass and construction industries,” says NGA's Haring.

Reach out to the local community

One of the biggest roadblocks to bringing glass and glazing education to young people, particularly young women, is a lack of existing learning opportunities, says Rehberger. She recommends that glass industry companies reach out to schools and local community groups to offer to help bring glass and glazing demonstrations and education directly to students.

To aid in these efforts, NGA is creating resources for companies to help educate young people, including a new web page, www.glass.org/become-glazier, that uses video, career stats and personal stories to highlight the opportunities the glazing trade offers. “Our industry offers a path to build a long-term, rewarding career without stacking up college debt, and it is this message that we need to share with the public,” says Jenni Chase, VP of Workforce Development for the NGA.

“You have the power to make it happen. It just takes doing it. We can't wait around for someone else to do it,” Rehberger says. “After Camp NAWIC, I contacted five or six schools to say, ‘We did this. Are you interested in having us do this with your students?’ I already have one response saying yes, they are interested.”

Camp NAWIC's glass event was held at the Associated General Contractors of America facility, and featured glass and materials donated by Frameless Hardware Company and Glasswerks Los Angeles. ■



Never Compromise

Products:

Como Hinges
Glass-to-Glass Clamps
U-Channels
Square Pull Handles



800.421.6144 • crlaurence.com
showers@crlaurence.com

As the trusted industry leader for over 60 years, you can count on CRL for durable, time-tested products and an unmatched selection of popular finishes.

CRL offers a complete line of **Frameless Shower Hardware:**

- Sliding shower door systems
- Shower door hinges
- Towel bars and grab bars
- Pull handles and knobs
- Headers, support bars, and more

YOUR ASSOCIATION AT WORK

NEED-TO-KNOW INFORMATION
 FROM THE NGA

NEW JOINT GTP PUBLISHED

The National Glass Association and the Fenestration & Glazing Industry Alliance announced the joint publication of a new Glass Technical Paper, or GTP, “Compatibility Testing of Insulating Glass PIB Primary Sealant with Respect to Glazing Materials.” The new GTP discusses methods of compatibility testing of glazing components with respect to polyisobutylene, or PIB, primary sealant in an IGU, recommends the use of the ift Rosenheim test method, outlines the effects of incompatible glazing materials, and addresses other factors that may affect compatibility. ■



DOWNLOAD
 THE NEW
 GTP AT
 GLASS.ORG

BLUEPRINT FOR COLLABORATION

NGA hosted a panel during the AIA A’23 Conference in San Francisco, held June 6-8, continuing its commitment to educating architects on the potential of glass and glazing products in design. “Blueprint for Collaboration: The path towards sustainable facades” focused on the future of glass in design for energy performance and sustainability and featured panelists who represent a different area of expertise within the industry. Panelists included Stanley Yee with Dow, Lisa Rammig with Eckersley O’Callaghan, Sophie Pennetier with Enclos, Chris Fronsoe with Vitro, Mark Suehiro with C.R. Laurence and Mike Turner with YKK AP, and was moderated by Tom Culp, owner of Birch Point Consulting LLC and NGA’s energy code consultant. ■

SPECIAL GLASS INDUSTRY TRENDS WEBINAR

A special edition of NGA’s Thirsty Thursday webinar series—10 Industry Metrics You Should be Watching—delved into the state of the global supply chain, the direction of the construction economy, and how current design and building trends are driving glass product development. Presented by Katy Devlin, NGA content director and editor-in-chief of Glass Magazine, the webinar is a gift to NGA members and the industry at large as part of our 75th Anniversary celebration.

Watch the webinar at glass.org/ondemand-webinars. ■



TESTING BALLISTIC GLASS

NGA’s Andrew Haring, vice president of business development, had a good time testing ballistic glass in Texas, while at the same time amplifying the message that our schools need bullet-resistant glazing. With reps from NGA member Quikserv Inc./United States Bullet Proofing, he conducted unofficial testing (to ASTM standards) on UL 752 level 1 and level 8 ballistic glass.

“Yes, it was fun. More importantly, we’re leveraging this opportunity to bring attention to the need for bullet-resistant glazing in our schools,” says Haring. NGA staff and member company representatives also addressed the glass industry’s role in school security during the second annual Glass & Glazing Advocacy Days, held in Washington, D.C. ■



GLASS INFORMATIONAL BULLETIN



BIM for Glass and Glazing Systems

Building Information Modeling, or BIM, is an intelligent, model-based process that starts in the early stages of planning and design. It is used through construction and can also be used throughout the operational management stages. BIM can even handle potential adaptive reuse through the life cycle of the building.

BIM is more than three-dimensional models. BIM projects can use intelligent objects that display the proper graphics at different scales, represent accurate geometry, and can be rich with manufacturer product data.

Power of BIM lies in the “I”

BIM objects can contain:

- Graphical information such as visualization and constructability analysis through 3D detailing.
- Non-graphical information such as performance and material data, and the ability to schedule construction and provide digital material takeoffs with increased precision.

Example of BIM LOD Specification for Exterior Windows

100	Solid mass model representing overall building volume; or schematic wall elements that are not distinguishable by type or material. Assembly depth/thickness and locations are still flexible.
200	Windows approximate in terms of location, size, count and assembly type. Units are modeled as a simple, monolithic component; or represented with simple frame and glazing. Nominal unit size is provided.
300	Units are modeled based on specified location and nominal size. Outer geometry of window frame elements and glazing modeled to within $\frac{1}{8}$ inch precision. Nominal face dimensions and thickness of glazing. Structural support for window wall system, if applicable. Spacing, location, size and orientations of mullions. Operable components defined (windows, louvers and doors) and included in model. Required non-graphical information associated with model elements includes: <ul style="list-style-type: none"> • Aesthetic characteristics (finishes, glass types) • Performance characteristics (U-value, wind loading, blast resistance, structural, air, thermal, water, sound) • Functionality of the window (fixed, casement, hung, projected, sliding)
350	Mullion shapes and geometry defined. Attachment or anchorage layout and types defined. Actual panel dimensions.
400	Complete mullion extrusion profiles. Glazing sub-components (gaskets). Interface details between wall systems (within) and wall and support systems, including sealants, end dams, flashing and membranes.

GLASS INFORMATIONAL BULLETIN—BIM FOR GLASS AND GLAZING SYSTEMS

- Linked information such as manufacturers' websites, warranties and sustainability information.

This information can help align the expectations of architects, engineers, contractors, building owners, specialty consultants, product manufacturers and fabricators. Equally important, once a project is completed, BIM can provide building owners and facility managers with a complete "as-built" source for a more comprehensive building management solution.

BIM is a concept

There are many platforms that can be integrated together for a BIM-based project approach. There is BIM modeling (a process) of a BIM model (a building) using generic or project-specific manufacturer-supplied BIM objects (a product). Beyond providing geometry, the BIM model, full of data-rich objects, can be leveraged for extractable and measurable data used to analyze spatial relationships, orientation and surrounding site conditions; determine building energy usage and light analysis; and quantities and properties for building material takeoffs.

There are several software platforms classified as "BIM-capable," including, but not limited to, Autodesk, Revit, ArchiCAD, Vectorworks and AECOsim.

BIM process

The architect may begin with a schematic model by using masses or real elements in a BIM environment. This model is used to address site conditions and determine the size and shape of the building. During schematic design, scheduling and estimating can be

incorporated into the elements of the model. This ensures that, as different schematic design options are investigated, estimates for time and cost can be constantly updated.

Industry collaboration teams may be assembled to work on system designs, glass and framing dimensions, and initial structural analysis. These elements can influence the look and feel of the building while optimizing the glazing system design that could trigger additional fabrication or installation costs. This period in the design phase may be the proper time to involve technical staff from manufacturers, fabricators and glazing contractors.

Once the construction drawings are released and the construction phase begins, software platforms including, but not limited to, Navisworks, BIM 360TM Glue and VEO™ may be employed. These allow for the architectural model to overlay with individual sub-contractor models to view clashes, inspect layout geometry and review interfaces with surrounding materials. BIM-enabled planning of erection and installation sequences optimize where the different trades operate within the building during construction. This can result in fewer workers on-site, with faster installation and safer job sites. Because of the efficiencies of BIM, some general contractors are using a BIM approach even if the architect did not start the project in BIM. These types of efforts also push the adoption of BIM further down the supply chain.

Level of development

The level of development, or LOD, is commonly mistaken for level of detail, which generally refers to how detailed

This Glass Informational Bulletin is excerpted from the NGA Glass Technical Paper IN05-17 (2022) "Overview of Building Information Modeling (BIM) for Glass and Glazing Systems." Download at glass.org/store.



or intricate an individual model element is. The LOD describes to what extent the element has been "thought through" and finalized. Adherence to the specified LOD will ensure that the proper level of effort is expended in each stage of the design.

A model may look like it is a final product in the final location, but based on the LOD the design team can know to what degree they can rely on the information when using the model. A clear LOD definition allows downstream users the ability to understand the usability and the limitations of the models they are receiving. BIMForum has a detailed LOD specification at bimforum.org/lof that breaks down different building systems and how the LODs apply to a specific system.

Conclusion

Utilizing BIM properly can reduce costs by the early detection of conflicts, errors and other design issues and facilitate collaboration between building project teams. ■

EVERYTHING DOOR HARDWARE

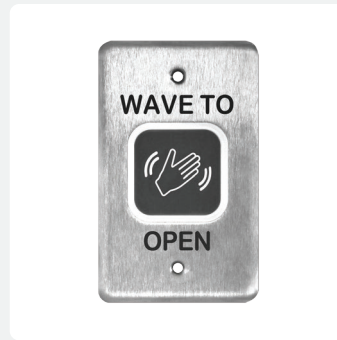
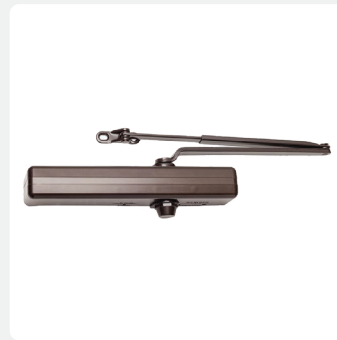
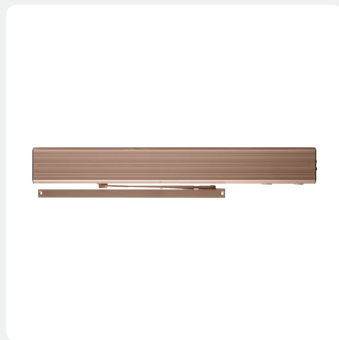
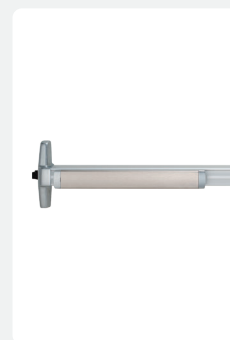



#TrustedGlobalSupplier

A Life Dedicated to Glass



Semavi Yorgancilar, a glass guru, was born in Izmir, Turkey, in 1959. He began his career in 1976 with his family's glass trading business. In 1989, he established "Orim" a home appliances glass company in Bolu/Turkey, marking his entry into the manufacturing sector. In 2003, he sold Orim to the German company Schott, serving as its CEO for three years. In response to the call for "return to the kitchens" from his business partners, Yorgancilar re-entered the home appliances sector after 10 years. He ultimately emerged as a leader in the sector, solidifying their position in the market.

Throughout his career, Yorgancilar played an active role in industry associations and contributed significantly to export efforts. He was the founding president of the Association of Home Appliances Sub-Industries for three years and served on several industrial and trade chamber committees.

Yorgancilar has a deep passion for glass, believing it to be a unique material with unparalleled properties. He credits his love for glass as a key factor in his company's success. His main driving force is achieving excellence. As his company grows into a trusted, global supplier, Yorgancilar believes in pushing boundaries and embracing changes swiftly, an attitude that has benefited his firm greatly.

In line with this, Yorgancilar has transformed from a glass processor to a glass manufacturer in the industry, with the establishment of a washing machine door glass production facility in the Manisa Organized Industrial Zone. This has positioned them as a one-stop partner for their business associates in the home appliances sector. The company recently doubled its workforce, reflecting its ambitious growth trajectory. Over the past decade, they have sold over 250 million units of glass to the home appliances sector. Refusing to stay in the comfort zone, Yorgancilar places immense trust in his team and emphasizes agile organizational structures. In a rapidly changing world, Yorgancilar underscores the importance of adaptability and continual evolution in business. His confidence in their future success remains unwavering, as he believes in the power of a progressive team and an ever-evolving company.



A Vision Sculpted in Glass

Established in 1974, Yorglass is a global leader in industrial glass processing and flat glass trading. The company's diverse product line, organized into four distinct units: Yorglass Trade, Yorglass Saturated, Yorglass Food Displays and Yorglass Home Appliances, caters to both national and international markets.

Operating seven zero-waste certified factories across four Turkish cities, Yorglass serves over 60 countries worldwide, offering a vast catalog of more than 150 glass types. In 2022, the company achieved significant growth, boosting their export ratio to 48% through production-based sales, and achieving a total export figure of \$77 million. Today, Yorglass holds a 50% domestic market share and over 30% in Europe, underscoring their commitment to continual expansion and innovation.

Where Sustainability Meets Aesthetic Brilliance

Yorglass Satina, a global leader in the glass processing sector, is renowned for its innovative "zero pollution" treatment facility, launched in 2010. Further emphasizing its commitment to sustainability, it became the first to receive the 'Carbon Footprint Certificate' in its industry in 2017. It is Turkey's first decorative glass production facility, is famous for its unique offerings such as decorative glass, double-sided glass, and non-slip floor glasses.

The Perfect Harmony of Aesthetics and Safety at the Highest Level

Yorglass Satina's Yorfloor merges safety and style with its certified anti-slip flooring and stair glass. Its patterns, achieving the highest R13 safety level from Europe's IFA, are adaptable for various settings. With custom-cut designs for global projects, Yorfloor balances beauty, safety, and practicality, revolutionizing the industry.

Embrace the Beauty of Nature with Yorglass's Decorative Glass Series

Experience the allure of nature with Yorglass's Decorative Glass Series. Inspired by the natural world, these elegant and functional designs enhance any space, from cabinets to bathrooms and stair railings. With a wide range of patterns and versatile application options, Yorglass brings the energy of nature into your home, creating timeless and captivating interiors.

safesky Pattern Matters



Yorglass introduces Safe Sky, a revolutionary bird-friendly glass solution that goes beyond traditional approaches. With a unique perspective on patterns, Safe Sky sets itself apart from other bird-friendly glass products in the market.

Bird collisions with standard glass pose a significant threat to avian populations worldwide, resulting in a staggering loss of billions of birds each year. Yorglass recognizes the urgency of addressing this critical issue and has developed Safe Sky with a threat level of 16, prioritizing the safety and well-being of our feathered friends.

Safe Sky incorporates advanced technology and utilizes specially designed patterns on the glass surface. These patterns play a crucial role in enhancing visibility for flying birds, allowing them to detect and avoid potential collisions. Through extensive testing, Yorglass has demonstrated that Safe Sky significantly reduces the risk of bird strikes by an impressive 84%.

What sets Safe Sky apart is its innovative approach to patterns. Yorglass understands that pattern matters in creating effective bird-friendly glass. By carefully considering the design and placement of patterns, Safe Sky maximizes its visibility to birds, offering a higher level of protection compared to conventional solutions.

Beyond its immediate benefits for bird conservation, Safe Sky contributes to a more sustainable future. By reducing bird collisions, it mitigates the environmental impact and associated costs of bird mortality. Yorglass's dedication to sustainable manufacturing practices and ecological balance is reflected in their commitment to creating bird-friendly architecture. With Safe Sky, Yorglass is leading the way in redefining bird-friendly glass and setting new industry standards. This innovative solution showcases their unwavering commitment to protecting birdlife, promoting sustainable practices, and fostering a harmonious coexistence between human-made structures and the natural world.

The most-clicked news stories on GlassMagazine.com, brought to you by **GLASS MAGAZINE WEEKLY** *

Oldcastle BuildingEnvelope Acquires Syracuse Glass Co.

Oldcastle BuildingEnvelope Inc. completed the acquisition of Syracuse Glass Co. Founded in 1909, SGC is an independent fabricator and distributor of architectural glass and aluminum products serving glazing contractors, manufacturers and glass retailers throughout Upstate New York, Eastern Pennsylvania and New England. OBE acquired SGC to enhance its presence in the Northeast region of the U.S.

“Syracuse Glass Company has delivered high-quality products and excellent customer service in its markets for more than a century,” says Bruno Biasiotta, CEO of OBE. “We are excited about the prospect of leveraging our collective cultures and capabilities to build on SGC’s great reputation. This acquisition will allow our teams to provide industry-leading glazing solutions to better serve our customers and partners and help them be successful.”

PGT Innovations Announces Ownership Stake in Eco Enterprises

PGT Innovations acquired the remaining outstanding 25% ownership interest in Eco Enterprises LLC. PGTI first acquired a 75% ownership stake in Eco Enterprises in 2021 to accelerate revenue growth, expand margins and strengthen the supply chain by adding glass production capacity while diversifying and bolstering product lines to provide opportunities in residential and commercial markets. Eco is a brand of aluminum, impact-resistant windows and doors primarily serving the South Florida region, with manufacturing

and glass processing facilities in Miami, Florida.

Arty Feles Steps Down as President of CRL

In an organizational statement from Oldcastle BuildingEnvelope sent to employees, CEO Bruno Biasiotta announced that Arty Feles, president, C.R. Laurence Co., informed OBE that he is resigning from the company due to personal circumstances, effective immediately. The company has accepted his resignation and wishes him the best in his future endeavors, says Biasiotta.

A spokesperson from CRL released the following statement:

“We will be filling the vacated president role, as well as expanding our CRL management team to support our current business and future acquisitions, which we are actively pursuing.

CRL remains steadfastly committed to our customers, our industry and our people who have built our great business. We continue to make investments in our footprint to better serve our customers with a broad portfolio of innovative products and technologies, along with best-in-class lead times and product availability.”

TotalEnergies to Supply Certified Sustainable Biomethane to Saint-Gobain

TotalEnergies signed a 100-gigawatt-hours biomethane purchase agreement with Saint-Gobain France for a three-year period starting in 2024. TotalEnergies will produce the biomethane at its BioBéarn biomethane

plant, which came on stream at the beginning of the year. The production is certified sustainable by ISCC1 under the highest sustainability criteria of the European Union REDII Directive.

TotalEnergies is one of the first producers to obtain this certification in France, say officials. By acquiring the Guarantees of Origin, and thanks to its sustainable certification, Saint-Gobain will be able to attest, within the framework of the EU Emissions Trading Scheme, to the decarbonization of its energy consumption in France. This contract is also an example of a purely commercial sale—non-subsidized—of biomethane.

NSG Group Opens New Solar Array

NSG Group announced that a 750-kilowatt photovoltaic solar system opened in May at its Aken facility in Saxony-Anhalt, Germany.

The new array owned by Aken, with 1,500 PV modules installed on the open space and roof of the plant, will provide 650,000 kilowatt hours, around 10% of the annual consumption of the Aken facility in the future. The electricity generated by the array system on weekends and during periods of shutdown is fed into the public power grid. This project is a part of NSG Group’s solar and energy savings projects.

AGC Glass Europe Produces Low-Carbon Flat Glass at Second Plant

The AGC Glass Europe facility in Seingbouse, France, now produces low-carbon Planibel Clearlite, a float glass whose carbon dioxide footprint has been reduced by more than 40%.

CUT! BREAK! RECYCLE! REPEAT!

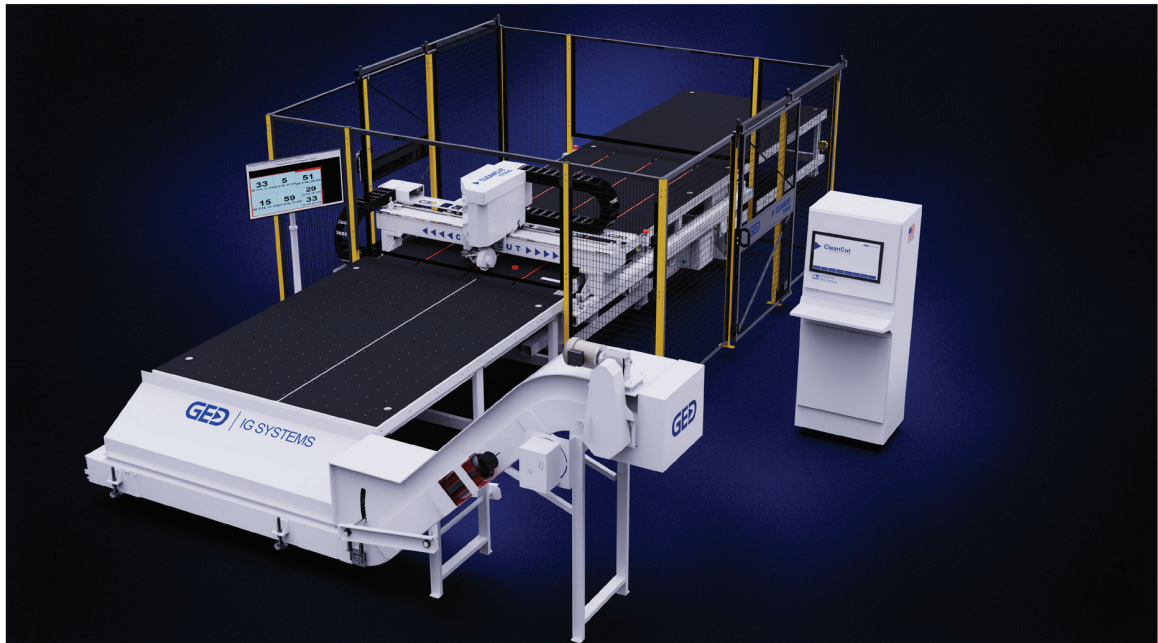

CleanCut™ 1700 & 1800 Series

- ✓ Highest glass yields with extremely fast sheet process time with or without deletion
- ✓ Single bridge cutting table with proprietary edge deletion head option
- ✓ True servo drive of GED patented deletion head
- ✓ Programmable cutting & deletion force uses electro-pneumatic actuation

Glass Culet System

- ✓ High-speed glass fragmentation
- ✓ Engineered for CleanCut™ 1700/1800 Series
- ✓ Adaptable configurations options
- ✓ Increased dumping capacity



31100 Diamond Pkwy
Glenwillow, OH 44139
330-963-5401
www.GEDUSA.com



Scan the QR code
to learn more!



GED MADE,
SOLD, AND
SERVICED
IN THE USA!

JLM WHOLESALE

The Nation's Most Trusted
Security Door Hardware Wholesaler



With three distribution centers, most orders are available to ship next day! With shortened lead times, we make your job easier!

If you're looking for a leader in the security industry, we have what you need.

As security access control technology advances and standards change, JLM Wholesale has continued to stay up to date with the latest products and practices. Not only can we assist you in choosing the correct system components, but we can also provide technical guidance to meet your application requirements. Speak with our sales and technical associates for quotes, orders, or application assistance!



423.JLM.HELP
704.509.2940
www.jlmwholesale.com



NEWS TO KNOW

The production of low-carbon Planibel Clearlite yields no more than 15.4 pounds of CO₂ per square meter for glass that is 4 millimeters thick. AGC Glass Europe first produced this glass at its facility in Moustier, Belgium.

Vitro Releases Updated EPDs

Vitro Architectural Glass published updated versions of its Environmental Product Declarations for both flat and processed glass. These updates affirm that Vitro's glass products contain less embodied carbon than the industry standard for architectural glass products and indicate a lower embodied carbon value than previously reported in 2017 editions of these EPDs.

EPDs offer detailed data about the embodied carbon values and life-cycle impact on the environment of a wide range of architectural building products. As a standard measure of embodied carbon, EPDs calculate global warming potential value expressed as kilograms of CO₂ equivalent.

Vitro's 2023 EPDs indicate that its products contain 1350 kilograms of CO₂ equivalent, 6% lower than the National Glass Association's industry standard figure and an improvement on figures reported in 2017.

YKK AP and cove.tool Partner

YKK AP America Inc. partnered with cove.tool, a building design and construction software provider, to further facilitate how architects reach the carbon, cost and energy performance goals of YKK AP's projects.

YKK AP will integrate its products into cove.tool's recently launched revgen.tool, a cloud-based solution designed to make it easier for building product manufacturers to engage design teams earlier in the process as they select products. With this tool, architects can identify and align which YKK AP-specific products may fit best with their project using real-time, product and project-specific performance analysis.

Find us at GlassBuild 2023



Be more efficient and profitable when you digitally transform your business with our end-to-end software solutions designed for window, door and glass manufacturers.

We are now part of Cyncly. Look for our new logo at GlassBuild 2023 to find us in booth 1919.



Learn more at
events.cyncly.com

Salem Fabrication Technologies Group Acquires Used Glass Machinery Marketplace

Salem Fabrication Technologies Group Inc. is expanding its glass fabrication offerings by acquiring Glass Machinery Locator, a used equipment marketplace.

Glass Machinery Locator will become the used equipment division of Salem Fabrication Technologies Group. The re-branded and re-designed Glass Machinery Locator website will allow North American fabricators to buy or sell used tempering furnaces and fabrication equipment.

Glass Machinery Locator will liaise between buyers and sellers throughout the transaction process. Existing staff at divisions Salem Fabrication Supplies and HHH Equipment Resources will assist with developing pricing, identifying machine specs, deal communications, marketing efforts, shipping logistics, paperwork requirements and more.

Sisecam Takes First Steps into Field of Technology Development

Sisecam has signed a letter of intent to become an investor in Turkish technology company ICRON, an optimization platform service provider to numerous sectors for strategic and operational decision-making. The investment is part of Sisecam's determination to invest in promising technology-focused companies and projects, say officials.

According to the letter of intent signed by Sisecam's CEO Gorkem Elverici and ICRON's CEO Gurer Unal in Barcelona at Gartner's Supply Chain Expo 2023, if the negotiations end with an agreement, Sisecam will have an option right to increase its total stake in ICRON by up to 50% by 2027.

Glaston to Restructure Business Units, Executive Leadership

Glaston Corp. will reorganize its current structure to better serve its customers in the architectural, automotive, display and solar glass

processing markets. Glaston aims to accelerate the implementation of its strategy for the 2021–2025 period. Glaston's strategic financial and non-financial targets have not changed. The new organization is planned to come into effect on Oct. 1, 2023.

In the new structure, Glaston plans to form two business areas according to its customers' end-use segments: architecture and mobility, display, and solar. In addition, new global business functions, automation and innovation, and sourcing and supply chain management are planned. Sales and Services will continue as global functions, working together with the business areas. New appointments will also be added to Glaston's executive management group.

Paragon Tempered Glass Expands Ohio Facility

Paragon Tempered Glass will invest more than \$15 million and create 12 new jobs at its Paulding County, Ohio, facility to better meet customer demand, according to an article by RGP Northwest Ohio. The investment in new machinery aims to allow the glass fabricator to improve efficiencies to remain competitive and position for additional growth.

PEOPLE NEWS



Boland

Corey Boland joined **AGNORA** as CEO on May 23. Founder *Richard Wilson* is stepping back from his role as CEO but will continue to actively work with the board of directors. Boland comes to AGNORA with over 25 years of experience scaling manufacturing businesses across North America and into global markets.



Knisely

Scott Knisely is the new president and CEO of **Forel North America**. Knisely has over 15 years of experience in the glass industry, including

his position as vice president of sales for Forel NA these past years. He has previously held other senior leadership roles within the industry.

Marco Schiavon, former CEO of Forel NA, has finished his mission in the U.S. and will return permanently to Italy, where he will take up a management role at Forel headquarters.



Sciola

Nick Sciola Sr. will step down as CEO of **Hartung** and *Nick David Sciola* will take the helm as CEO in addition to his current responsibilities as president. After 35 years as CEO, Sciola Sr. will be transitioning to the role of executive chairman of the board.

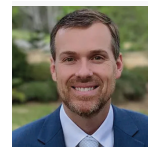

Taylor

NEXT Energy Technologies promoted *Brenton Taylor* to CEO. Taylor brings more than 20 years of experience in leadership, scaling manufacturing and commercialization of advanced technology innovations to NEXT. He most recently served as chief operating officer at NEXT. NEXT's founding CEO, Daniel Emmett, is stepping into the newly created position of executive chairman, supporting Taylor's transition. Emmett will continue to provide strategic support with fundraising, investor relations, high-value international markets and regulatory policy.



Stephens

PGT Innovations appointed *Chris J. Stephens Jr.* to its board of directors. He was appointed to serve on the board's audit committee, also effective June 28. He will serve as a Class III Director, and the board expects to nominate him to stand for election as a director at PGT Innovations' 2024 annual meeting.

Steve Wood joined **Roto North America** as a business development executive. In this position, Wood will be collaborating



Coast to Coast Sales & Rentals

Financing Available

GM 2000-26
Lift 2000 lbs. 26 feet high

GM 2000-16
Lift 2000 lbs. 16 feet high

GM 2000-12
Lift 2000 lbs. 12 feet high

GM 800
Lift 800 lbs. 10 feet high

GM 2000-16 WITH WINCH
Lift 2000 lbs. 16 feet high 2 ways!

GM 4000-12
Lift 4000 lbs. 12 feet high

GM 1200
Lift 1200 lbs. 10 feet high

THOM 2200
Fork-mounted manipulator
Lift 2200 lbs.

THOM 4000
Lifts 4000 lbs.

PL 1000
Lift 1000 lbs. 12 feet high

SKYHOOK WPI
Crane attached manipulator
Lift 2800 lbs. or more

Made in the USA
Means Serviceability

More Done in Less Time

In the Factory or on the Job Site

CUSTOM SOLUTIONS AVAILABLE!

Which one works best for you?

Call or email Jerry j.nudi@ergorobotic.com 518-796-2179 ErgoRobotic.com

NEWS TO KNOW



Wood

with the sales team and promoting new business in the swing patio door and commercial aluminum market.

Wood will be reporting to Dan Gray, director of sales, Roto North America.



Pano

Vitro Architectural Glass

welcomed *Mark Pano* as national architectural manager for the New England region. Pano will identify and manage key construction projects in Connecticut, Maine, Massachusetts, New Hampshire, Rhode Island and Vermont, assisting and advising architects.

Before joining Vitro, Pano spent eight years in the coatings business at Fortune 500 companies, including RPM International and PPG.



Kumar

Kawneer named *Sneh Kumar* the director of global sustainability. He will develop and lead the company's sustainability strategy, focusing on product design, certification, and supply chain transparency and optimization.

Kumar has spent over 20 years in the manufacturing and building products industry. He has been involved in commercializing over 40 high-performance building facade products. Before his new role, Kumar was a product manager for Kawneer's curtain wall, window wall, sun control and finishes.



Wells

Giroux Glass hired *Walter Wells* as safety director. In this role, Wells is based out of the company's Los Angeles headquarters and travels

frequently to oversee safety operations on projects throughout Arizona, Nevada and Southern California.

Wells joined Giroux Glass in May 2023 after having worked previously for electrical contractor A.J. Kirkwood & Associates, initially as its safety manager, then as risk manager. Wells has certifications that include Construction Health and Safety Technician, Safety Trained Supervisor Construction, Construction Risk and Insurance Specialist and CPR, among many others issued by FEMA and OSHA.



Haines

U.S. Bullet Proofing, a division of Specialty Fenestration Group, announced that physical security solutions expert *Tom Haines* joined

the company as government business development manager.

Haines' role will include working



Available Door & Window System

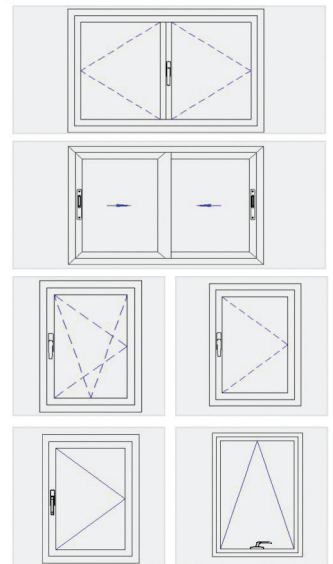

DOOR & WINDOW INTEGRATE SUPPLY AND SYSTEMATIC SOLUTION

- Integrated products for door & window
- Complete product structure
- Guarantee the integrated supply, supporting services and one-stop solution

KIN LONG
For Better Living

INTEGRATED EXPERTS ON CONSTRUCTION HARDWARE SOLUTIONS

Stock Code : 002791

www.kinlong.com

Contact : mail@kinlong.com

Gen II ArmorPlast® Aluminum-Framed Door Conversion Kit

Upgrade standard aluminum-framed storefront doors to high-security commercial entry doors with our Gen II conversion kits. Designed for 3/8", 3/4", and 1" ArmorPlast® forced entry ballistic infills.

The new Gen II security system has been engineered specifically for fast and easy installation. Just remove the glass stops and door glass, cut the conversion frames, and fasten the new security panel in place. Every order is shipped with detailed instructions and the Riot Glass product support staff is eager to help.

Our door conversion products are just part of the Gen II Storefront Security System.

Call or visit our website for full details and your new customer packet.



Riot Glass, LLC
17941 Brookshire Lane
Huntington Beach, CA 92647
800-580-2303



www.riotglass.com/b2b-signup/



Frameless Shower Door Specialists

Product Shown:
Capri Series Slider

Orders over \$100 ship **FREE**
in the Continental U.S.



HORIZON
ushorizon.com

P 877.728.3874 F 888.440.9567

NEWS TO KNOW

directly with government agencies, architects, contractors, purchasing agents and security experts within the government sector to develop design solutions for their upcoming projects. Haines has been involved with ballistic, blast, storm impact and forced-entry-rated windows and doors for the last 23 years.



Najmi

Unicel Architectural Corp.

announced it hired **Mariola Najmi** as Southwest U.S. regional sales manager, covering the states of Arizona, California and Nevada. Najmi has a decade of sales and specifications experience in the building materials industry, including as



Kirkman

regional sales manager for CMI Ltd. and Sto Corp.

As regional sales manager, Najmi will work closely with Unicel Architectural's range of glazing products.

The company also welcomed **Greg Kirkman** as regional sales manager for the mid-Atlantic region. Kirkman will be responsible for South Carolina, North Carolina, Virginia, Georgia, Tennessee, Maryland, Delaware and Washington, D.C., As regional sales manager, Kirkman will work closely with Unicel Architectural's range of glazing products, including Vision Control IGUs with integrated louvers.



Carlos

Joe Carlos has joined **GlasPro Inc.** as director of business development.

Carlos has over 35 years of glass industry experience covering the Western U.S. in many capacities. In the newly created role, he will leverage his expertise in identifying and creating sales opportunities for value-added architectural and decorative glass products. ■

Top Quality Glass Racks & Truck Bodies Since 1989

All racks ship fully assembled with detailed instructions. Factory authorized installations available across North America. Glass trucks built to order and in-stock for fast delivery.



MyGlassTruck

We design and build every glass rack in Glassboro, New Jersey. We use state-of-the-art equipment to ensure that every glass rack is built to the highest standard.



Visit our website.

(844) 364-4022
myglasstruck.com

MP-0539-B

Azo-Core™ | Thermal Barrier

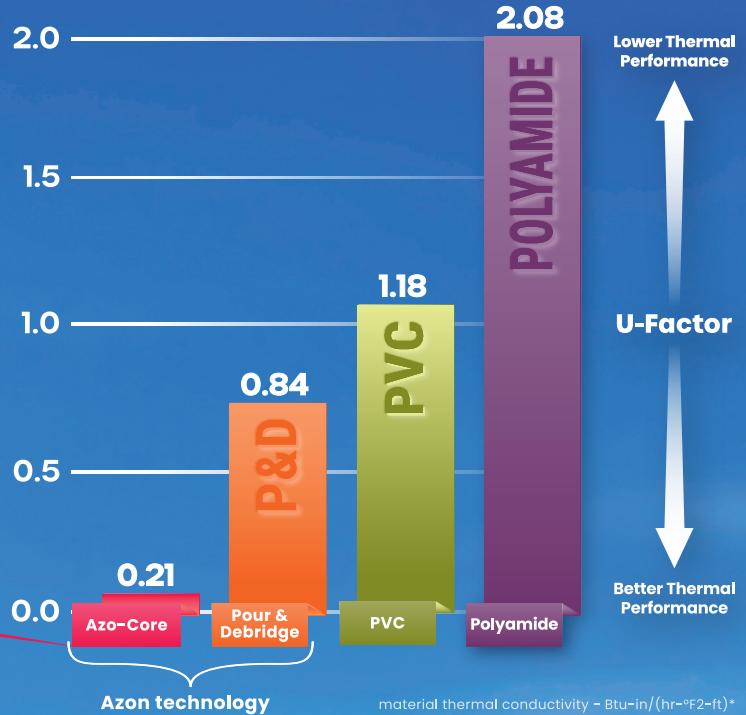

Azo-Core™ ultra-low conductance high-density polyurethane foam allows aluminum fenestration manufacturers to achieve the highest standards in energy efficiency, strength and durability.

Learn More: azonintl.com | 800.788.5942

Project: Aquatic V, Berkeley, CA
Product: Quaker C-Series Windows

Image by WEST BUILDERS / Quaker Windows and Doors



INNOVATION

SOWING THE SEEDS OF INNOVATION

INNOVATION ISN'T JUST LUCK—IT'S THE ORGANIZATIONAL DEDICATION TO CREATING CHANGE WITHIN YOUR MARKETPLACE **BY JIM NIXON**



What do you think of when you hear the word “innovation”?

It might be several things. It might be a flashy new gadget. An idea for how to do things differently.

A product or service that outperforms what's currently available in the marketplace.

Personally, I'm a fan of how innovation is defined by McKinsey & Co.: “Innovation is the systematic practice of developing and marketing breakthrough products and services for adoption by customers.”

In describing innovation as a “systematic practice,” this definition hits

on something important. Innovation isn't just a flash of inspiration. It's an organizational commitment to the fostering and development of new ideas. It's not one-and-done. It's ongoing investment and support, much like the continuous improvement journeys of our manufacturing floors. And it's not the job of just one person. It's close collaboration and resource sharing between cross-functional teams.

As the vice president of innovation and new markets for Quanex, it's my role to make these ideas a reality within our organization. And I believe that—to create real, meaningful progress within an industry that is constantly demanding it—these ideas are essential for all

stakeholders within the commercial glass industry. With all of this in mind, here are some ways we approach innovation, which you might also find helpful.

Bring your people together

Innovation can happen anywhere, at any level of your organization. But it can occur more frequently and naturally if different people and their varied skill sets aren't relegated to silos.

For example, suppose your company has several different business units. Each unit serves a discrete market, perhaps with some overlap between themselves here and there. They may also have their own teams of engineers, R&D professionals and others responsible for





35

ANNIVERSARY

XYG FLOAT GLASS

As we celebrate our **35th anniversary** this year, we are proud to reflect on our journey since the establishment in 1988. Join us as we mark this milestone at a celebration event to be held **mid-September in Wuhu, Anhui, China.**

XYG stands as the world's largest float glass manufacturer, attaining a remarkable daily melting capacity exceeding 28,000 tons. Our production capacity accounts for over 7% of the global float glass market supply.

Our extensive product range covers diverse selections, including clear float glass, low iron float glass, tinted float glass, Low-E glass, silver mirror and many more.

With 11 production facilities located in China and Malaysia, XYG provides a comprehensive array of options catering to various market needs and requirements.

FOR EVENT INFORMATION AND TO RSVP, PLEASE EMAIL US AT SALES@XYGGLASS.COM.



WWW.XINYIGLASS.COM/EN/

new product development, and perhaps they don't spend much time interacting with each other.

But the sharing of ideas between such teams can be a game-changer. Those teams may have distinct access to different processes, different tools, and of course, different ideas. The methods of one engineer may be eye-opening to that of his counterpart in the other business, and that can lead to potentially dramatic results in terms of new product development, material science or other areas of progress.

Alternatively, suppose your company serves a single market with a relatively narrow scope of products and solutions. The sharing of ideas is still absolutely critical. Your product engineer, for example, doesn't see the same things your production line technician sees every day. Encouraging the continuous sharing of ideas through channels like these can lead to new ideas that wouldn't have been discovered otherwise.

Failure is essential

Embracing and investing in new ideas requires understanding that not all will work. If they did, true innovation would be easy. Failure is a vital component of the innovation and learning cycle. If an organization is genuinely committed to innovating within its field, this should be an idea that's widely supported across all areas of your business.

This includes organizational support, starting from the top, for whatever the outcome. Failure does not signal that the time to invest in innovation is over, quite the contrary. Failure comes with its own value. Your teams will learn lessons they can apply to the next venture. What didn't work, and why. It's essential to uncovering true innovation.

Why innovation matters

The commercial glass and glazing industry is one of continuous change. New building codes continue to drive more stringent performance requirements.

Architectural designs grow bolder. And the demands of glass are increasingly complex. Consider: Windows and glass facades of the future could combine highly energy-efficient PVC framing, smart glass and solar components that help a home or building generate as much new energy as older technology used to lose through heat loss.

The future is limitless, but it's on us to keep investigating new opportunities, to seek out material choices that contribute to better thermal efficiency, architectural excellence and everything else that continues to push the glass industry forward. We also need to keep working together, collaborating with partners and vendors to identify the best ways to make it happen. ■

Jim Nixon is vice president of innovation and new markets at Quanex.

www.e-bentglass.com

One piece or thousands, our custom fabricated BENT GLASS is bringing form and function to the designs of tomorrow.



SRS Architectural Metals



Solar Innovations



Desert Star Glass Interiors



Architectural, Interior, Solar & Transport Applications



Precision Glass Bending

THE WORLD LEADER IN
CUSTOM FABRICATED
BENT GLASS

Precision Glass Bending Corporation
PO Box 1970, 3811 Hwy 10 West
Greenwood, AR 72936-1970
UNITED STATES OF AMERICA



Guardian SunGuard Select™ Fabricator









A CELEBRATION OF ARTISTIC INGENUITY

St. Petersburg, Florida is renowned for its vibrant art scene, featuring over 600 street murals. GGI contributed to this artistic landscape by fabricating 32 custom glass panels for a new public art display for the SunRunner Bus Rapid Transit system. As part of a \$44 million project to enhance the city, nationally recognized artist Catherine Woods was commissioned to design 16 art installments to be placed in bus shelters across a 10-mile corridor, capturing the essence of the surrounding neighborhoods. **Having worked with GGI on past projects, Woods knew GGI could bring her visions to life with Alice® Direct to Glass Printing.**

SunRunner Bus Rapid Transit Stations

Artwork by
Catherine Woods

Commissioned by
Pinellas Suncoast
Transit Authority
and the City of
St. Petersburg, Florida

Photography courtesy
of Catherine Woods

 800-431-2042  sales@generalglass.com  www.generalglass.com

©2023. All rights reserved. Alice® Direct to Glass Printing is a registered trademark of GGI.

SEE WHAT
GLASS
CAN DO
GGI



“ SUCCESSFUL SOFTWARE ADOPTION BY GLAZING COMPANIES CAN IMPROVE STAFF AND BUSINESS PERFORMANCE, MAKING THE ORGANIZATION MORE EFFICIENT AND PROFITABLE. ”

Introducing new software

You only have one chance to make a first impression, and that’s also true with launching new software. Whether teams are tech-savvy or loathe the thought of making a new application part of their work process, a proper introduction sets the stage for successful, long-term adoption.

Make it personal. Introduce the new software by focusing on benefits for the user, not the company. Start by outlining the specific benefits staff can expect to receive—saving time, gaining efficiency, streamlining laborious processes, eliminating paperwork, etc. Employees are much more enthusiastic about using new software when they understand how it will help them do their jobs better.

Companies that identify internal champions increase the likelihood that new software will be accepted and used. Consider starting with a focus group of employees to be trained on the latest software. They can advocate and support team members throughout the learning process. Starting small and then expanding to the entire staff is a proven method for successfully introducing new applications.

Training

Properly introducing new software is essential, but it is not a substitute for training. Only a well-thought-out training program will maximize the investment in new software, helping staff recognize its utility and empowering them to make it an integral part of their daily work lives.

When developing a training program,

IMPLEMENTING SOFTWARE SYSTEMS TO MAXIMIZE EFFICIENCY

YOU ONLY HAVE ONE CHANCE AT A FIRST IMPRESSION, AND THAT’S ALSO TRUE WITH LAUNCHING NEW SOFTWARE
BY MARK SUEHIRO



Computer software can be a powerful tool, but only if your teams put it to use. Successful introduction, training and support of new applications are required to achieve maximum value from investments in software. Whether the impetus to incorporate new apps into the business is meant to address profitability, efficiency issues, the shortage of skilled labor or strategic expansion, buy-in from staff is the lynchpin to success.

Some systems, like expense management or time management software, may be used across the entire team. Other systems may be utilized by individual groups, such as estimating or accounting software. No matter the number of users, software is only useful and valuable if team members put it to use.

SentryGlas® ionoplast interlayers

Kuraray Structural Interlayers

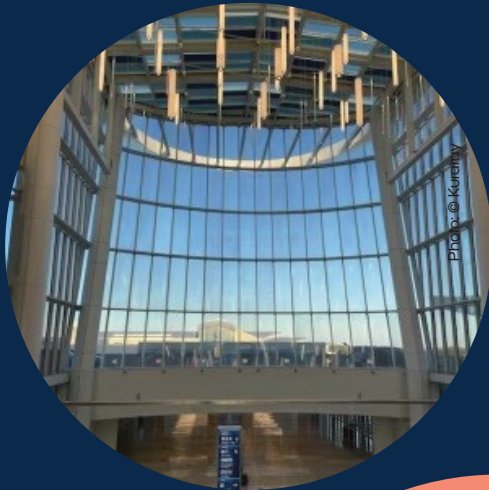

SentryGlas®, a premier product in the Kuraray Interlayer portfolio, has been instrumental in the completion of remarkable projects for the past 25 years due to its exceptional structural performance.

consult with the software maker. They will likely have training resources and perhaps even entire programs they can manage and implement for you. And they are certain to have support materials—cheat sheets, instructive videos, webinars—that will supplement the training process.

Most glazing companies discover they have two types of software users on their staff: tech embracers and tech abstainers/newbies. Effective training recognizes the differences in learning styles between these two audiences and will address the specific needs of both groups.

For tech embracers, training should focus on maximizing the utility of a software package. This group tends to be tech-savvy, thirsting for feature-level tips and tricks to deliver small but essential advantages. They can handle the details, and the company will benefit from their advanced abilities.

For tech abstainers/newbies, a different type of training program

is required to convert resistant or inexperienced staff into capable users. Focus on the basics, building a foundation with these individuals to use the core components of the software. Don't overload them with the minutiae, but help them understand the primary software features and functions supporting them in specific work duties.

Ongoing support

Fully leveraging the power of individual software programs takes time. It's an investment for both the company and the individual. Start by recognizing that training never stops. New hires must be brought up to speed on company systems. Current employees also benefit from periodic training to keep their skills sharp and add new technical abilities to their repertoire. Several online training resources are available, such as myglassclass.com for glaziers.

Establish systems to address ongoing questions and concerns through internal

company champions or the software maker. Provide avenues for continuing feedback. Your frontline staff may have insights into technical aspects of the software or new processes to better leverage the system's power. Tap into that knowledge by encouraging their input.

Key takeaways

Successful software adoption by glazing companies can improve staff and business performance, making the organization more efficient and profitable. Identifying a new software system that can deliver value is only the start. Developing a comprehensive plan for introducing the application, training the staff, and supporting their needs over the long term is the roadmap for making investments in new software pay off. ■

Mark Suehiro is director of architectural hardware and entrances for C.R. Laurence Co. He can be reached at mark_suehiro@crlaurence.com.

vetrotech.com

Fire Protective. 45 Minutes. Clearly.

Vetrotech Saint-Gobain, the company that pioneered PYROSWISS®, the world's first highly tempered clear fire-resistant safety glass, is pleased to announce that the product trusted by architects and glaziers for decades has been extended to a more versatile range of UL-listed fire-protective and impact-safety 45-minute applications.

On the safe side.

vetrotech
SAINT-GOBAIN

Take advanced design to new heights.

Push the boundaries of architectural design. Let our Advanced Engineering show how high-performance DOWSIL™ Brand Silicone Structural Glazing Sealants can be utilized for applications needing higher allowable stresses – *no special sealants required*. We can help you reach higher. Enable stronger possibilities for façade design. And do it with exceptional material science.

Let's work on building design innovation together.

dow.com/advanced-engineering



Seek Together™



Dow Building Science:
Collaborate to innovate.

Image: dow_53399227493. ©™ Trademark of The Dow Chemical Company ("Dow") or an affiliated company of Dow. © 2023 The Dow Chemical Company. All rights reserved. #17157M/#16677D (Glass0823). Form No. 63-7188-01 0222 AGP



7 GLASS MANUFACTURING HEAT SAFETY MYTHS

HEAT ILLNESS IS 100% PREVENTABLE, SO TAKE EVERY STEP NECESSARY TO KEEP YOUR GLASS WORKERS SAFE IN THE HEAT **BY M.B. SUTHERLAND**

The increased focus on heat safety in the workplace is a welcome change that saves lives. But for workers in hot indoor facilities like glass manufacturing plants, it can feel like all the emphasis is on outdoor work. Hot indoor environments can be just as dangerous and fraught with avoidable heat safety misconceptions. Here are seven indoor heat safety myths to watch for.

MYTH #1 **Indoor facilities don't get hot enough to cause severe heat illness.**

If you work in a non-air-conditioned glass plant or in a climate where the air conditioning has trouble keeping up, we're betting you already knew this one was false. While none of the risks

below are exclusive to indoors, any of the following can increase your workers' likelihood of indoor heat illness, up to and including heat stroke.

Heat and humidity. Consider both heat and humidity when you schedule breaks and cooling measures since humidity impedes the body's ability to release heat through sweating.

Heavy exertion. Hard work coupled with high facility temperatures can be deadly as workers accumulate heat internally and externally.

Heavy machinery/radiant heat. Heavy machinery churning away in your facilities can act like little indoor suns, throwing off heat and increasing danger for your workers.

Confined spaces. Workers in small, enclosed areas may be at higher risk of

overheating due to poor air quality.

Medication and alcohol. Even medications as common as over-the-counter allergy medicine or having a few beers at a party the night before can lower a person's ability to regulate body heat.

Underlying health conditions. Heat safety isn't one-size-fits-all. Medical conditions like high blood pressure, diabetes or being overweight can increase the likelihood of heat illness.

MYTH #2 **You can pick just one spot to measure the temperature in your facility.**

Things like hot machinery, airflow, the size of a space and the number of people working in a space can make heat safety hazards very different in one area of your facility versus another.

Use a wet bulb globe temperature monitor indoors and outdoors to measure air temperature, humidity, radiant heat and airflow in various locations. This small but powerful device gives you a much more accurate measure of the actual heat load in various areas than a standard thermometer can.

MYTH #3 **Air-conditioned breakrooms prevent heat illness.**

The availability of nearby air conditioning is one advantage of hot indoor work over hot outdoor work. But air-conditioned break and lunchrooms will only help prevent heat illness if workers can access them at frequent intervals. If you wait for symptoms of heat illness to appear, you already need more interventions.

As indoor temperatures rise, increase the number of air-conditioned breaks in the day and create body-cooling stations in these areas with cold cotton towels in refrigerators or freezers. Ensure employees whose jobs require extensive PPE or other gear have time to remove it, cool down, and put it all back on properly within their break times without rushing.

Practically perfect in every situation



we shape glass

Pratica Plus is the CNC workcentre by Bottero available in 3000 and 4000mm sizes with 3 or 4 axes.

It can support a high number of processing operations in a flexible and qualitatively exemplary way, such as straight and shape cutting, drilling, grinding, bevelling, writing, engraving and much more.

The ease and intuitiveness of the software represents a strong point for these machines that can be used in any advanced glass factory.

The high quality standard of the **Pratica Plus** range is particularly noticeable in the care for details: each component is carefully studied and designed to offer performance measuring up to the most demanding requirements, making the machine even safer and more performing.

Bottero machining centers are extremely powerful machines that can operate on both glass and stone, making them even more flexible to use.

The standard version of the machine is able to perform the following operations on glass sheets:

- Milling on the sheet with a rectilinear or curvilinear path.
- Edging and radial polishing on a straight and/or curved path on the edge of the sheet.
- Drilling and/or countersinking perpendicular to the surface of the sheet.
- Writing and drawing on the top side of the sheet.

By using optional aggregates the possibilities are expanded to:

- Cutting with a straight diamond disc.
- Cutting with a straight diamond disc angled at 45°.
- Writing and drawing on the side surface of the sheet.
- Straight or curved bevelling on the top side of the sheet.
- Straight and/or curved engraving and/or engraving on the top side of the sheet.
- Drilling on the underside of the sheet.



Myth #4
Body cooling PPE is only for outdoor work.

Since most of the workday is spent not on an air-conditioned break, provide body-cooling PPE that workers can activate and reactivate throughout the day. Specialty cooling garments are designed to harness the natural power of evaporation for cooling without the need for chemical coatings that can make other products feel slimy. Able to be activated repeatedly on the job with any water temperature, these materials cool to as low as 30 degrees Fahrenheit below average body temperature in under a minute and stay cool for up to two hours.

MYTH #5
Hazardous work requires heavy PPE, and getting overheated is part of the job.

This myth is common as the dangers in glass plants sometimes require

almost full-body coverage for safety. But new technologies and manufacturing techniques have made bulky, itchy protective clothing a thing of the past.

Cut-resistant protective tops are now available that are 30% lighter weight while providing the highest ANSI Level A9 cut levels. New sleeves and gloves on the market also provide ANSI A9 protection and are paired with new glove-coating technologies and cut-resistant materials that can eliminate the hot and uncomfortable practice of double-gloving.

MYTH #6
Workers have more access to water in indoor facilities, and everyone is hydrated, so heat illness isn't a concern.

It's essential to address the fact that, in many facilities, workers do not have adequate access to hydration throughout the day, and managing this should be

job one. But on top of that, a crucial heat safety lesson that many environmental health and safety professionals miss is that even well-hydrated workers can suffer any heat illness, up to and including heat stroke.

A worker in a hot environment, exerting heavily, covered in PPE will need more than hydration alone to prevent heat illness.

MYTH #7
Getting someone into a cool room is adequate to treat heat illness.

Getting a sufferer into a cooler environment is just one weapon in your arsenal against the damage that heat illness can cause. Pay attention to the symptoms the victim is showing and treat accordingly. ■

M.B. Sutherland is the senior safety writer at Magid. Learn more at magidglove.com, or 800/444-8030.

Glasshape®

Delivering Bent Glass with Excellence

BENT GLASS SOLUTIONS

Digital Site Measures for Bent Glass Projects

Client: Jaroff Design
 Project: Waterline Square Amenities - Nexus
 Photo: Evan Joseph

Seattle : 206 538 5416
 New York : 332 255 6319

🌐 : glasshape.com ✉ : info@glasshape.com

Smart Glazier Connect

Are you ready to move your glass fabrication business into the **digital age**?

Connect your customers to your cutting table with the world's leading

FLAT GLASS E-COMMERCE PLATFORM

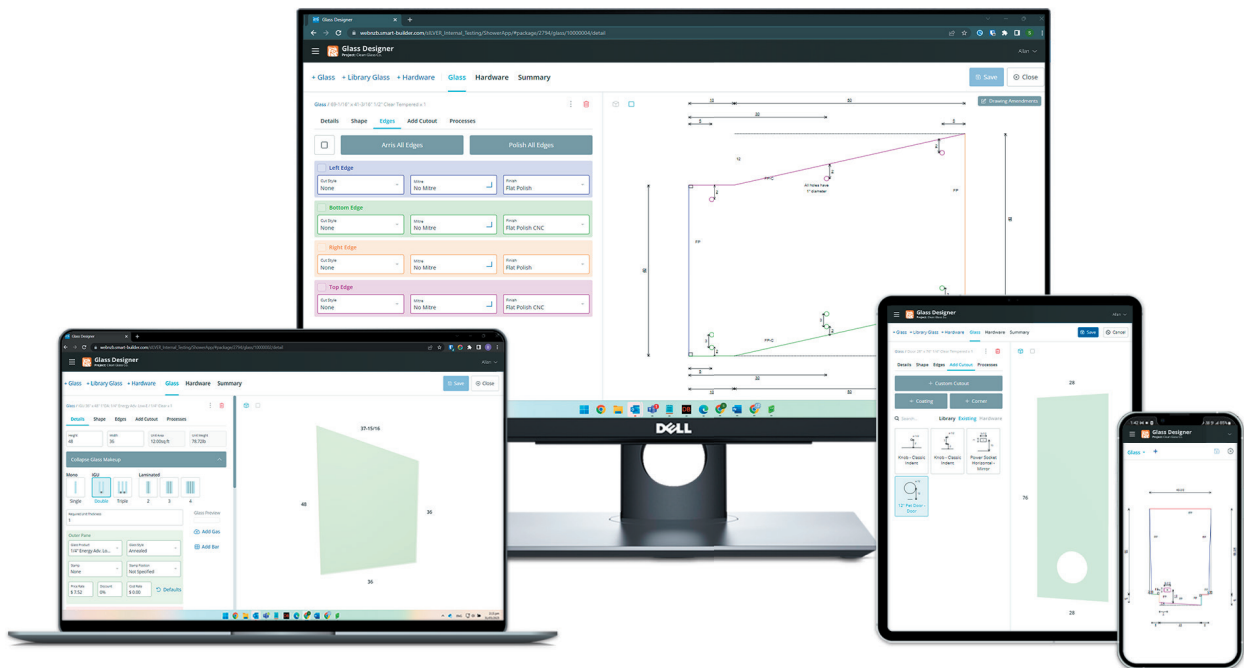

Visit us at GlassBuild - Booth 1813

Smart Glazier Connect is a brand-new, browser-based, online ordering portal.

Get electronic orders from your customers for heavy glass through to custom laminates & IG units, sent from the site or office, using mobile, tablet, or any PC/Mac.



✉ sales@smartglazier.com

🖱 smartglazier.com/fabricators



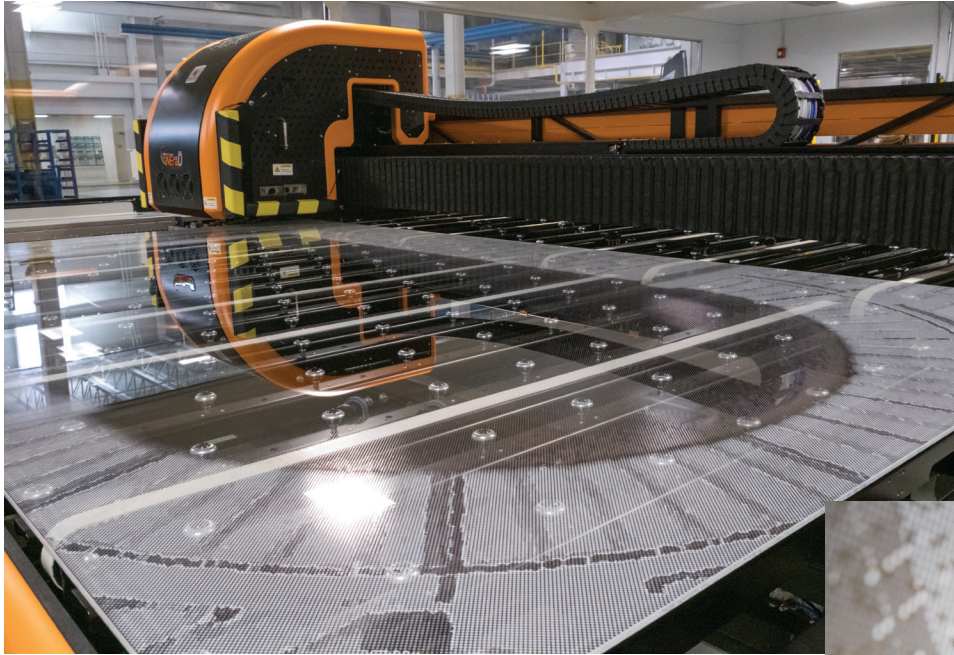

Ceramic frit digital printed glass at AGNORA's glass fabrication facility.

A CHECKLIST FOR GLASS PRINTING

DEMISTIFYING DIGITAL AND DECORATIVE PRINTING ON FLAT ARCHITECTURAL GLASS
BY ADAM MITCHELL



When I started at AGNORA, I was thrilled to see the large-format, direct-to-substrate capabilities in-house. Having spent over 15 years in large-format printing, I thought I knew printing through and through. Still, Joe Lindsey and the print team at AGNORA showed me the subtle and not-so-subtle differences between traditional large-format printing and printing on glass.

This article aims to provide insights into the different print processes available for architectural glass—the strengths of each, and considerations that must be considered when bridging client needs with fabricator capabilities. Having some or all of these considerations answered will streamline

the print process and, with a bit of hard work, exceed expectations.

Why print on glass?

In short, printing on glass allows designers to create transformative glass spaces. Glass can become a canvas for creating unique designs to be incorporated into public art features and into buildings such as hospitals, transportation stations and building lobbies.

I spoke with Michael Saroka, CEO of Goldray Glass, to gain another perspective. Goldray Glass is another leading company that has been printing decorative glass for construction projects across North America for more than 37 years. Saroka has been on the shop floor

since he was knee-high, learning about the relationship with paints, glass and heat. He helped me to expand on the benefits of printing on glass.

“The current generation of digital printers allow designers to expand the decorative canvas to both exterior and interior projects,” he says. “Digital printing’s flexibility means it can be used monolithically or included in laminated and insulating glass units.”

How is glass printing different?

Coming from the traditional print industry, when considering large format for a project, there are standards that are adhered to. For example, Pantone is the go-to color library, often integrated with color and tone





Ceramic frit digitally printed decorative glass encloses the new One Young Street building in Kitchener, Ontario. Photo courtesy of AGNORA.

GET TO KNOW THE PRINTING OPTIONS

One of the first things to note is the variation in ink and print types and their applications. The following table breaks down the difference between ceramic and organic-based ink systems, which are both used for digital printing on glass.

SOURCE: GOLDRAY GLASS AND AGNORA.

	CERAMIC FRIT	ORGANIC INK
MANUFACTURING PROCESS	Ceramic ink applied to glass is heated to 1,100 degrees F (600 degrees C) and becomes fused to the glass. In other words, it must be tempered to cure. Notes: <ul style="list-style-type: none"> • Easily customizable • Highly versatile • Low volume 	Organic printing technology allows for direct-to-glass printing after the tempering process, or without tempering at all. Notes: <ul style="list-style-type: none"> • Easily customizable • Highly versatile • Low volume
LIFE EXPECTANCY	Unlimited, because the frit is fused to the glass.	Many years when not in the presence of natural light or exposure to UV. Suggested for interior use only.
RESISTANCE TO ULTRAVIOLET	Ceramic frit does not break down when exposed to UV rays.	Organic ink may break down in the presence of UV, over time.
COLOR MATCH	Matches very well with dark colors. Limited gamut when extending into yellow and red.	Exceptional color-matching capabilities.

reproduction certifications such as G7. Further, extended color ranges beyond CMYK (cyan, magenta, yellow and black) are also commonplace, and you may find yourself with a wider, more precise color gamut by adding light cyan, orange or light magentas. Do you require Coca-Cola red? Walmart blue? No problem. High-end print providers can nail those brand specifics.

However, digital printing on glass does not follow these traditional, entrenched standards.

- The printers are bespoke, require larger investments and can be narrower in their capabilities.
- The glass printing industry is a specialty area, supported by a dedicated team of skilled technical experts.
- The print engines or “rip software” are customized and require inherently steep learning curves and specific knowledge.

- With glass printing, the color gamut can vary and is often proprietary to the print manufacturer.
- Takeovers and mergers appear to be higher in the glass printing industry as small printer companies get bought, resulting in changes in the supply chain (communication, parts, ink).
- Finally, glass acts very differently with inks than other materials such as vinyl or fabrics, demanding more innovative, solution-oriented thinking. “Color matching, vibrancy, fading and pixelated imagery are real challenges facing designers and printers,” Saroka says.

Why am I sharing these seemingly broad drawbacks? Because it lays the foundation for understanding what to expect from direct-to-glass printing, the challenges these types of specialty fabricators face, and the dedication you

can expect from the companies that do it.

“Like all technology, it is important to not only understand what is possible but have experienced operators and product designers guiding the creation of the product. It is not enough to own the technology; owning a chisel does not make you a sculptor,” says Saroka.

Application considerations

If you require custom digital printing, you may have to ask a few questions to know what you’ll be receiving from your print partner.

Will the project be indoor or outdoor and be exposed to natural light?

Ceramic inks are not prone to fading. However, organic inks may fade over long periods, more noticeably in reds and yellows.

Will passersby have a close-up view of the glass?

AUTOMATE ALUMINUM FABRICATION



/ CNC MACHINING CENTERS

/ CUTTING SOLUTIONS

/ CUSTOM PROCESSORS

/ JOSEPHMACHINE.COM

/ CONTACT / 717.432.3442



WE INSPECT YOUR GLASS

The Best in Class Inspection Solutions from Viprotron

THE NEW MILESTONE

Viprotron is proud to add a **new innovation** to its product range. Our strong focus on defect detection in insulated glass, has steadily expanded over the years to include cutting, fabrication, lamination and finally tempering.

Now we are introducing new, advanced technology for improving tempering defect detection. We will enhance our award-winning Anisotropy + Haze Scanner by adding a **Roller Wave** and **Edge Kink Scanner** to our system. All five functions (Roller Wave/Edge Kink, Anisotropy, Haze, Brightfield & Reflection Channel for optical defects) are available in one complete package or as individual scanners.

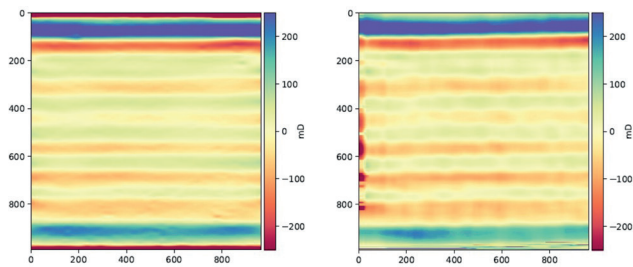
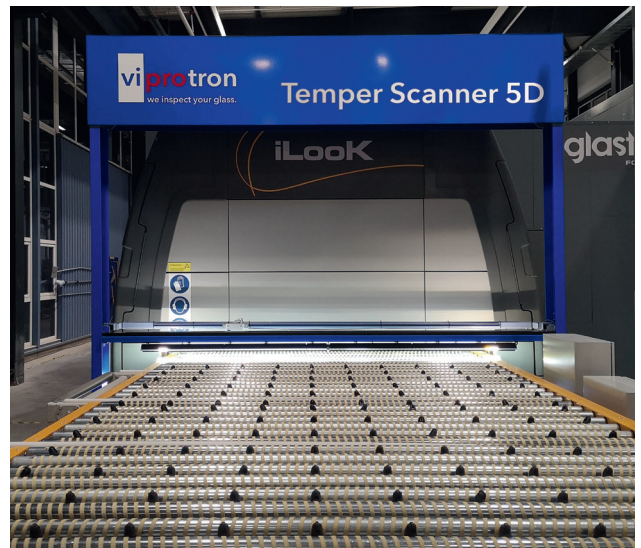

TACTILE MEASUREMENT

VIPROTRON

NOW YOU HAVE A BETTER CHOICE

Our new, innovative and patented technology is producing excellent results when compared to actual tactile measurements of Rollerwave and Kink distortion. Our glass inspection systems provide customers with the information that they need to improve their quality and processes. You can rely on Viprotron to provide the data you need to bring your Tempering quality to the higher level that your customers demand from you.

Call us to learn more about our Temper Scanner 5D!

CONTACT US TODAY

Viprotron North America Inc.
Cell: (313) 384 3855
Mail: ric.schmidt@viprotron.com
www.viprotron.com

Indoor applications are typically viewed close-up and require higher-resolution artwork to be of acceptable quality.

What is the required color?

Opacity refers to how “see-through” the ink is, with 100% opacity equalling full coverage, while 0% is no ink at all. Both digital print methods provide values from 0 to 100%.

Gradients refer to the “shading” from one opacity value to another for a given area. Both print technologies provide robust gradients devoid of “banding.”

Color gamut is the range of available colors. Organic inks provide a wider, impactful gamut of color and can easily match existing color libraries. Ceramic inks have a reduced range of colors, notably reds and yellows; however, specialty inks can be mixed to achieve a desired color.

What are the design requirements?

Photorealism is possible in digital printing. Reproduction of photographs and their inherent range of color are available for both ink types. Organic inks tend to reproduce real-life images better due to color. Both ink systems produce abstract (illustrations, drawings, vector artwork) well.

Alignment should also be considered if a single image is spread across multiple lites. How will the image be aligned across the lite? Will the image be cropped in the case of different-sized lites?

Edges must also be taken into account. Is the print against the edge? Is there a chamfer? Is the glass custom in shape, and do edges need to align perfectly if no mullion is present?

What are the size requirements?

The overall available sizes for North American facilities are 130 by 300 inches

for ceramic-based inks and 77 by 118 inches for organic-based inks.

Experience matters

Working with companies you know will be at your side when you need a replacement, answer questions, and being there “tomorrow” goes a long way in overall support. A broken lite many years down the road may be a pain to match; however, high-quality glass printers may output a replacement, especially if they were the originating firm. ■

Editor’s Note: The views expressed in contributed columns to Glass Magazine belong to the author and do not reflect the position of the National Glass Association or its technical committees

Adam Mitchell is marketing manager for AGNORA. He can be reached at amitchell@agnora.com.

BURKLE
NORTH AMERICA, INC.

**NEXT LEVEL
LAMINATING**

4 KEY BENEFITS OF CHOOSING THE BURKLE IFL SYSTEM

1 FASTER
PRODUCTION
TIME

2 LOWER
ENERGY
COSTS

3 IMPROVED
PRODUCT
QUALITY

4 REDUCE
LABOR UP
TO 50%+

SEE US AT GLASSBUILD - EXHIBIT #1241

LEARN MORE AT
WWW.BURKLE.TECH/US-EN/



Photos courtesy of Michael Moran/OTTO

GREAT GLAZING: LINCOLN CENTER DAVID GEFFEN HALL

SOCIAL/PUBLIC SPACES:
TOD WILLIAMS BILLIE TSIEN
ARCHITECTS

CONCERT HALL
DIAMOND SCHMITT

PHOTOS
MICHAEL MORAN

THE BASICS
The new Lincoln Center David Geffen Hall, designed by Diamond Schmitt and Tod Williams Billie Tsien Architects, was decades in the works but completed ahead of schedule and under budget since the pandemic forced the closure of the Avery Fisher Hall.

THE DESIGN
The first priority was to improve and revitalize the acoustics inside the main theater, to make sure it was the best-in-class acoustic experience for the New York Philharmonic. What resulted is a completely new theater inside the building, not just a renovation, creating an intimate and inclusive experience for the audience.

THE GLASS
Everything in the building, from door handles and floorboards to railings, feels reassuringly solid. Pulp Studio created over 8,700 square feet of flat and bent laminated glass railings and guardrails, chemically strengthened for the tight 8-inch radii specified for the job. Pulp Studio's proprietary Precision Edge® technology was used to post-polish the glass edgework for a refined look using its two-decade-old proven process. In addition, guardrail glass was added with a specially etched, low-iron, laminated glass, finished with a digital design for an enhanced level of privacy and intimacy.

Learn more at pulpstudio.com, 310/815-4999. ■

SPONSORED CONTENT

PULPSTUDIO

**Read the bonus
advertising
content on
the next page**





Flemish Low Iron



Reeded Low Iron

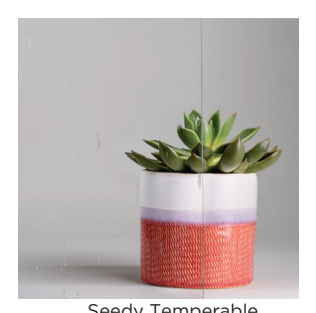

Seedy Temperable



Stylos S Low Iron

WE MAKE SOURCING SPECIALTY GLASS EASY

Sourcing textured patterned, antique mirror, fire-rated, and other specialty glass products can become a time-consuming and costly effort. GGI makes ordering mixed loads fast and easy, saving you time and money. Get what you need, when you need it.



Scan QR code to view all textured patterns.

REFLECTIONS ON MIRROR



ANSWERS TO TOP GLASS INDUSTRY
QUESTIONS ON FLAT GLASS MIRROR



The Marcus restaurant at the Four Seasons Montreal Hotel features bronze mirrors throughout its entrance and clear mirror in the main dining space. Walker Glass supplied the mirrors.



The technical services team of the National Glass Association maintains the NGA Codes & Standards Help Center to provide general guidance to its member community. The following is a compilation of inquiries about flat glass mirror. To read more Q&A or to submit a question, visit [glass.org/member-help-center](https://www.glass.org/member-help-center) (NGA member log-in required).

IS MIRROR GLASS REQUIRED TO BE SAFETY GLAZING?

Yes. Referring to 2021 International Building Code (IBC) Section 2406.1, mirror glass in hazardous locations is required to be safety glazing, except when mounted or hung on a surface that provides a continuous backing support.

For mirror applications, a safe alternative to tempering is to use a “safety backing.” The safety backing is an adhesive film made from polypropylene applied to the back surface of the mirror. If impacted, the safety backing will help keep glass shards in place while also helping to control moisture that can cause the mirror to deteriorate.

IS SAFETY BACKING REQUIRED ON MIRRORS THAT ARE MOUNTED

LESS THAN 18 INCHES FROM THE GROUND IF IT WILL BE ADHERED TO THE WALL WITH MASTIC?

It depends. The mirror installation could be exempt from safety glazing requirements if the mastic provides a “continuous backing support.” Continuous backing support is not defined in the IBC. It could be assumed if the mastic covers the entire back of the mirror without gaps or hollow areas between the mirror and substrate, that may be considered continuous backing support. However, it sounds like a fairly large mirror if it’s being mounted less than 18 inches from the ground. Even if technically exempt, especially for tall or large mirrors, it is preferred to have mirrors that will not break into dangerous shards if impacted, so safety backing is recommended.

IS IT REALLY NECESSARY TO USE MECHANICAL SUPPORTS WHEN INSTALLING A MIRROR? CAN AN ADHESIVE BE USED TO MOUNT THE MIRROR INSTEAD?

Mechanical means of installation, such as J-moldings, clips and screws, or framing are recommended for most applications. J-molding should have weep holes. Mirrors should always have a 3-millimeter (0.12-inch) neoprene setting pad between the mirror and clip or molding used. Tapes, adhesives or mastics can be used in addition to mechanical means of installation. If using adhesives in the installation process, use those that are “neutral cure.” Ensure that the adhesive selected is compatible with the mirror backing. Avoid adhesives containing strong solvents or acids like acetone, toluene,



An installation featuring UltraMirror from Guardian Glass.

methylene chloride, acetic acid, etc., as these can severely damage mirror backings. Refer to specific adhesive manufacturer’s instructions for further information.

CAN MIRROR GLASS BE INSTALLED IN EGRESS DOORS?

The IBC does not permit mirrored glass on egress doors, as egress doors must be easily recognized as points of exit from the building in case of emergency.

HOW SHOULD MIRRORS BE CLEANED?

Care should always be taken to avoid getting the edges of the mirror wet with any liquid or substance. This can result in damage to the mirror edges, commonly called “black edge.” Should mirror edges become wet, they should be dried off immediately.

The best cleaner for a mirror is clean, warm water used with a soft, lint-free cloth. Wring all water from the cloth before wiping the mirror. Dry the mirror immediately with a dry lint-free cloth. Don’t use acid or alkali cleaners for

mirror cleanup after installation. Either substance can attack the front surface and edges as well as the backing of the mirror. Abrasive cleaners are not recommended on any mirror surface.

CAN I RECYCLE BROKEN MIRROR GLASS?

Unfortunately, most community recycling programs can only take standard bottles and jars, not sheet glass, Pyrex or mirror. Instead of throwing old mirrors away, they could be repurposed into new home projects or artwork such as mirror tiles, garden or greenhouse accents, or mosaic applications.

NEW MIRROR MANUAL

The NGA Fabricating Committee has a task group working to compile a Mirror Reference Manual. Learn more about the task group and how to get involved at glass.org/advocacy/get-involved/committees. ■



Learn about additional benefits available to NGA Members

NGA TECHNICAL VOLUNTEERS

Volunteers from the following NGA member companies are working to develop the Mirror Reference Manual. Get involved at glass.org/advocacy/get-involved/committees.

- Guardian Glass
- NSG Group / Pilkington
- Trulite Glass & Aluminum Solutions
- Virginia Glass Products
- Vitro Architectural Glass
- Walker Glass

LEARN MORE ABOUT FLAT GLASS MIRROR FROM THESE ADDITIONAL FREE RESOURCES FROM NGA



Proper Procedures for Cleaning Flat Glass Mirrors (FB06-05)



Proper Procedures for Fabrication of Flat Glass Mirrors (FB22-09)



Proper Procedures for Receiving, Storage and Transportation of Flat Glass Mirrors (FB30-11)



The Reusability and Recyclability of Mirror Products (FB38-14)



Understanding Reflective Distortion in Mirror Installations (FB58-18)



Installation Techniques Designed to Prolong the Life of Flat Glass Mirrors (FB21-09)



LATTUADA
+ADDING VALUE

AUTOMATION SOLUTIONS

EVERY CUSTOMER IS UNIQUE TO US...
AS UNIQUE AS OUR AUTOMATION SOLUTIONS

Robotics, A-WR & i-AL Systems, Augmented Reality and IoT: a beating heart of innovation and technology revolutionising glass and stone processing. Lattuada brings companies into the world of Industry 4.0, by making every machine a concentrate of precision, productivity and automation.

AUTOMATIC MACHINES A-WR & i-AL Systems

ROBOTIC SOLUTIONS
AR ASSISTANCE
IOT

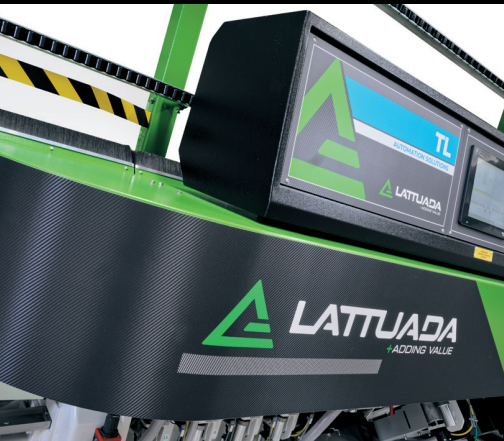

LATTUADA NORTH AMERICA, INC.
www.lattuada-na.com



ADELIO LATTUADA Srl
www.adeliolattuada.com



See you at Vitrum
SEPTEMBER 5-8, 2023
FIERA MILANO - RHO
HALL 7 - BOOTH C02 - E11



GLASS MAGAZINE AWARDS 2023

GLASS CAN DO EVERYTHING

WINNERS SHOW THAT GLASS IS A MULTIFUNCTIONAL MARVEL

BY NORAH DICK

EVERYTHING

The 2023 Glass Magazine Award winners provide incontrovertible proof that glass is beautiful and can do almost anything inside and outside of a building. The seven project and six product award winners represent the full gamut of what glass and metal systems have to offer to the spaces where we live, learn, work and play.

Winning projects and products continue to showcase sustainable and green solutions, including energy efficiency, as well as provide a connection between indoor and outdoor spaces through the use of glass.

Demonstrated in several winning projects, decorative glass continues to be an integral design element, providing color, interest and elegance.

Product award winners continue to emphasize speed and ease of use for a less-skilled labor force, and an industry still facing unpredictable lead times and staffing.

Glass remains structurally important to the exterior as well, as seen in the new awards category this year for "Best Curved Glass." The decision to debut a new category was based on the impressive range of nominated projects that featured curved and bent glass, which speaks to the engineering prowess and innovation of the industry.

No less impressive is the industry expertise that makes this competition possible. The Glass Magazine editorial staff would again like to thank this year's 19 project award judges, who reviewed the nominated projects. We also thank the glass industry voting public for taking the time to select this year's product award winners from the nominations.

We know many companies have outstanding projects and products yet to be completed or released. To participate in next year's Glass Magazine Awards, contact Senior Editor Norah Dick at ndick@glass.org.



PROJECT OF
THE YEAR

THE PROJECTS

► BEST FEAT OF ENGINEERING

1550 ALBERNI STREET

Nominating Companies

Glass 3 Enterprises
Kuraray

Location

Vancouver

Winning Team

CONTRACT GLAZIER, METAL SYSTEMS MANUFACTURER:
Flynn Group of Companies
ARCHITECT: Kengo Kuma & Associates
FAÇADE DESIGNER: RDH
FABRICATED GLASS SUPPLIER: Glass 3 Enterprises
INTERLAYER SUPPLIER: Kuraray
PHOTO CREDIT: Graham Handford





A

Asymmetry meets style in the new 43-story, mixed-use tower that makes a striking addition to the Vancouver skyline. Drawing inspiration from the surrounding environment, the complex façade appears as though it is constantly shifting, incorporating wooded balconies as a natural element.

“Form, form and form. A complex design with multiple materials, shapes and structures. Totally brilliant,” says Glass Magazine Awards judge Martin Bracamonte, vice president of marketing and innovation, Vitro Architectural Glass.

“The shape of this building is awesome, and to be able to use glass with this design is phenomenal,” says Glass Magazine Awards judge Tom O’Malley, founding partner, director of sales, Clover Architectural Products.



“FORM, FORM AND FORM. A COMPLEX DESIGN WITH MULTIPLE MATERIALS, SHAPES AND STRUCTURES. TOTALLY BRILLIANT.”

Contract glazier Flynn Group of Companies, working with fabricated glass supplier Glass 3 Enterprises, provided and installed triple insulating glass units to the podium and first few floors of the massive building.

Glass 3 Enterprises supplied several glass systems, including vertical glass fins, the largest measuring 36 by 274 inches. Fins were comprised of four layers of 12-mm low iron, tempered with a 090 SentryGlas interlayer. The company also provided insulating glass units measuring 89 by 226 inches, laminated with Trosifol Clear PVB.

“This project appears to be a strong architectural statement fully integrated with complex engineering implementation at many different scales across the building structure and envelope,” says Steve Selkowitz, consultant,

Building Technology and Urban Systems Division, Lawrence Berkeley National Laboratory.

Façade designer RDH worked closely with the glass fabricator to ensure quality assurance. “Our team’s ability to create an ongoing relationship with the manufacturer has been a significant aspect of the project’s production success to date,” say RDH officials, on the company’s website.

“We were present during the development, testing, and manufacturing stages to provide quality assurance and to support the manufacturer’s development of quality control processes. We also managed the design and construction of a performance mockup of the enclosure system to illustrate the standard that must be met during construction.”



FIRST
RUNNER-UP,
PROJECT OF
THE YEAR



▼
BEST DECORATIVE
GLASS APPLICATION

THE AUDREY HEPURN PAVILION

Nominating Companies

Eastman Chemical Co.
Goldray Glass

Location

Los Angeles

Winning Team

ARCHITECT: Shohei Shigematsu,

with Gruen Associates of Los Angeles and Office of Metropolitan Architecture

GLAZING CONTRACTOR: Steel City Glass

GLASS LAMINATOR: Goldray Glass

INTERLAYER SUPPLIER: Eastman Chemical Co.

STRUCTURAL ENGINEERING: ARUP

PHOTO CREDIT: Jason O'Rear



“THIS IS AN INCREDIBLY VISUAL AND INTERESTING STRUCTURE THAT REALLY PUTS THE GLASS AT THE FOCAL POINT FOR ANYONE THAT ENTERS.”



History and modernity both find expression in the Audrey Irmas Pavilion, a glowing green glass trapezoidal terrace recessed into the side of Wilshire Boulevard Temple's historic Erika J. Glazer Family Campus in Los Angeles. The temple has been a cornerstone of the Jewish community since its opening in 1892.



“This is an incredibly visual and interesting structure that really puts the glass at the focal point for anyone that enters,” says Glass Magazine Awards judge Sara Barchak, marketing communications manager, EFCO Corp.

Designed to host religious and cultural activities, celebrations and performances, the 55,000-square-foot, three-story pavilion features three harmonious gathering spaces—each with a distinct scale and spatial character.

Shohei Shigematsu's pavilion design uses the trapezoidal window as a counterpoint pop of color that simultaneously aligns with the design elements of the Byzantine-Revival style building. The dramatic green laminated glass coordinates with the building's dome, while the pavilion's geometric lines, neutral facade dotted with hexagonal shapes and windows, and recessed green glass terrace create a unique contrast to the traditionally styled temple.

The strategic use of green laminated glass ties the three levels of the pavilion together—from the exterior panels visible from Wilshire Boulevard to the interior partitions within the Diane & Guilford Glazer Chapel to the insulating glass units of the West Terrace—while allowing in

daylight and providing views of Los Angeles, the Hollywood sign and the mountains north of the city.

Glass Magazine Award judge Jennifer Highfield, Architectural Design Associate, Viracon, noted the impressive eight-layer stack of Vanceva PVB interlayer, which allowed for the signature glowing green glass. The stack was combined with a metal mesh interlayer.

The exterior panels, interior partitions of the Diane & Guilford Glazer Chapel, and the insulating, laminated green glass units in the West Terrace were fabricated by Goldray Glass and installed by Steel City Glass alongside MATT Construction.



► **BEST PROTECTIVE GLAZING PROJECT**

ORLANDO INTERNATIONAL AIRPORT, TERMINAL C



Nominating Company

Tecnoglass, nominated on behalf of Kuraray

Location

Orlando

Winning Team

- GLASS FABRICATOR: Tecnoglass
- INTERLAYER SUPPLIER: Kuraray
- CONTRACT GLAZIER: Physical Security
- GLASS SUPPLIER: Architectural Aluminum Techniques
- METAL SYSTEM MANUFACTURER: BCI Sun Metals
- ARCHITECT: Fentress Architects
- PHOTO CREDIT: Greg Angel

Orlando's International Airport now features a new addition: Terminal C, representing a \$2.8 billion investment, with 15 gates serving 10-to-12-million passengers annually. And, located as it is in Orlando, hurricane resistance and impact ratings are a major concern for glass systems.

"We all know Florida sets standards for protective

glazing, [and] the scope of the Orlando Airport project clearly makes it a winner," says Glass Magazine Award judge Pete de Gorter, vice president, DeGorter Inc.

Glass fabricator Tecnoglass selected Kuraray's SentryGlas to meet standards and certifications, including Florida Product Approval and Notice of Acceptance High Velocity Hurricane Zone (NOA – HVHZ) for Miami-Dade County and Broward County.

"Working with Tecnoglass

has been a collaborative and synergistic experience for a very long time. With their expertise in designing glass systems and a deep understanding of the technical requirements for hurricane glazing, we supply interlayers that meet their exact needs," says Tameca Triplett, marketing communications coordinator, Kuraray.

The exterior facade and interior railings were both glazed with 0.060 SentryGlas. Kuraray officials worked closely with Tecnoglass as

the fabricator conducted air, water and structural testing, as well as impact and cyclic load tests to ensure that the system's performance aligns with the stringent regulations of Miami-Dade County.

Glass Magazine Award judge Nataline Lomedico, president and CEO, Giroux Glass, also recognized the project's sustainability strategies, including water-reduction features, solar panels, responsive lighting, and the use of nontoxic and natural materials.

Inspired performance



SunGuard® SNR 35

**Reflect vibrance + priorities for
comfort, efficiency, sustainability.**

33% visible light transmission

35% reflectivity out

0.17 SHGC



Learn more at
guardianglass.com

©2023 Guardian Glass, LLC

Images are artistic renderings
intended to represent the reflected
and transmitted color of the glass in real
use conditions. Actual results may vary.





▼
BEST PROJECT
TEAM

BOLEY ELEMENTARY SCHOOL



▼
The new daylit and colorful interior of Boley Elementary School complements the heart-warming story of this project, winner of the “Best Project Team” award. After a fire destroyed the school in 2019, the local school board worked to get the school rebuilt as quickly as possible. Officials from TBA Studios, an

architecture firm located only two miles from the school, say they felt obligated to help the students and teachers get back to learning as soon as possible.

To complete the rebuild by the start of the 2023 school year, the firm had to work quickly, and closely, with other stakeholders. “Working

closely with the contractor and the owner throughout the entire construction process allowed TBA to ensure a tighter schedule while also ensuring quality design and giving back Boley the best school it could be after such devastation,” say officials from TBA Studio.

Daylight, and therefore





Nominating Company

TBA Studio

Location

West Munroe, Louisiana

Winning Team

GLASS MANUFACTURER: Vitro Architectural Glass

INTERLAYER SUPPLIER: Eastman Chemical Co.

CONTRACT GLAZIER: ACME Glass and Mirror

ARCHITECT: TBA Studio

PHOTO CREDIT: Matthew Cassity

glass, was integral to the design. Large spaces, like the library, were designed facing North to allow light to flood the space without glare or high heat gain. “The use of light entering the building was important to TBA and the client to ensure that natural light entered to create a bright, welcoming and happier

school,” say TBA officials.

Pops of color, accomplished with Eastman Chemical Co.’s Vanceva interlayers, highlight several rooms in the new building. “The rooms are filled with colors promoting playfulness and positivity, which are ideal for elementary school environments,” officials say.

“Nothing says ‘team’ like experts helping get their own community back on their feet. Loved the open spaces, color laminated glass and natural lighting. Loved the sense of community even more,” says Glass Magazine Awards judge Pete de Gorter, vice president, DeGorter Inc.



▼
**BEST GREEN
PROJECT**

CENTER OF DEVELOPING ENTREPRENEURS





Nominating Company

Kawneer

Location

Charlottesville, Virginia

Winning Team

GLASS MANUFACTURER: Guardian Glass

ALUMINUM SYSTEMS: Kawneer Co.

CONTRACT GLAZIER: Glass and Metals Inc.

GLASS FABRICATOR: Rochester Insulated Glass

ARCHITECTS: Wolf Ackerman, Eskew Dumez Ripple

PHOTO CREDIT: Alan Karchmer

Being green can be good for business—quite literally, in the case of the new Center of Developing Entrepreneurs, or CODE, which features outdoor and flexible community and office spaces for established and emerging businesses. Also green in architectural design, CODE aims to be LEED Gold certified, and several of nominating company Kawneer's thermally broken systems helped the project take home the "Best Green Project" award this year.

"The intermixing of live foliage on rooftops and the many other sustainable features really puts this project above the rest," says Glass Magazine Awards judge Sara Barchak, marketing

communications manager, EFCO Corp.

Designed to meet AIA's 2030 efficiency and thermal performance challenge, the architectural team and specialty engineering consultants ran an intensive energy model during the design process, say Kawneer officials. "All façade elements are integrated into a thermally broken, insulated metal panel layer," say Kawneer officials. "At the same time, the planes of insulating glass line up with the plane of building insulation. Jam anchors allowed the plane of insulation to be unbroken between window and facade insulation, avoiding a thermal bridge."

Located in downtown Char-

lottesville, Virginia, the building envelope design draws from the brick cladding and punched window openings of the surrounding historical context but is implemented with a modern rain screen to achieve high levels of insulation and thermal performance while providing defense-in-depth against water intrusion, say officials from Kawneer.

Relying on passive design, operable windows combine with the building's orientation to draw cool breezes from the mountains and funnel them through the narrow floorplate. Analysis estimates that 40% of the year, the building should require neither cooling nor heating, says the company.



▼
**BEST
CURVED
GLASS**

JEFFERSON HEALTH HONICKMAN CENTER

Nominating Company

Cristacurva

Location

Philadelphia

Winning Team

ARCHITECTS: ENNEAD
Architects, Stantec

BUILDING ENCLOSURE

CONSULTANT: Heintges

TOWER

CONTRACT GLAZIER: New
Hudson Facades

GLASS MANUFACTURER: AGC
Europe

CURVED GLASS FABRICATOR:
Cristacurva

FLAT GLASS FABRICATOR:
Interpane-AGC

STOREFRONT

CONTRACT GLAZIER: National
Glass and Metal

GLASS MANUFACTURER:
Guardian Glass

GLASS FABRICATOR:
Cristacurva

PHOTO CREDIT: Torsten Zech



▼
A

20-story medical facility located in central Philadelphia, the new Jefferson Health Honickman Center features a rippling façade with curved glass fabricated by Cristacurva. It is this year's winner in a new category, "Best Curved Glass."

Glass Magazine Awards judge Jacob Kasbrick, commercial segment and technical services manager, Guardian Glass, praised the façade's unique aesthetics. "The tower façade has constant movement from the bent [insulating glass units], unlike most buildings, which use a corner to accent the bent aesthetic," he says. "The color consistency from the tower glass in reflection was nicely balanced as normally extreme angles could provide undesirable reflected colors, while this façade looks very uniform and inviting."

The undulating façade was designed to be textured, says Gabriela Dávila, marketing, Cristacurva, with flat glass adjacent to curved concave units. Achieving a low-emissivity coating on surface No. 2 of the concave curved units is courtesy of a breakthrough technology that the company developed a few years ago, says Dávila.

"Before this new technology was available, the only way to have curved concave glass was to make curved convex glass and flip it inside-out," says Dávila. "On monolithic or uncoated assemblies, this is not an issue, but when there is a high-performance low-e coating, it was a problem because it meant that the coating would be on surface No. 3 of the [insulating glass unit] instead of surface No. 2."

"Most coatings don't look and perform the same on surface No. 2, so this created visual inconsistencies and created a detrimental impact on the wall performance," Dávila says. Since the company's innovation, bending glass concave with a surface No. 2 low-e coating is possible.



HERC-DOOR®

U.S. Patent Nos. 11,060,341 and 11,187,323

STEINCRAFT®

PANIC HANDLES | UL CERTIFIED SA45616

Experience & Innovation

Empowering the Glass & Glazing Industry Through Exceptional Solutions

FHC ALUMINUM®	STEINCRAFT®	G50™ SERIES
ACHIEVE®	ASPIRE™	G52™ SERIES
HERC-DOOR®	MAGNALINK®	LUXE™

Product Innovation remains a foundational pillar of FHC's business model, it's in our DNA. But "Innovation" means more than simply creating something new - it means creating value. We listen to the industry, and create solutions delivering better quality products, with shorter-lead times, and faster installations.

FHC ADVANCE HERC-DOOR®
 Door Rail & Patch Rail Fittings

HERC-DOOR®

REVOLUTIONARY UNITIZING GASKET
 Patented Dual-Inclined Centering Control System Adds to Increase Strength.

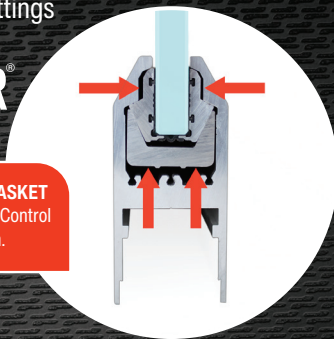

NGA AWARD WINNER FOR

3 CONSECUTIVE YEARS!

Visit Us at Booth 1205

EXHIBITOR

GlassBuild AMERICA.

THE GLASS, WINDOW & DOOR EXPO
 October 31 - November 2, 2023 • Atlanta, GA

FHC®
 FRAMELESS HARDWARE COMPANY

The Glazing Supply Company

EXPERIENCE AND INNOVATION

(888) 295-4531 | FHC-USA.COM | info@fhc-usa.com



► BEST GLASS INTERIOR

DAVID GEFFEN HALL

Described as “the new cultural home for New York” by Lincoln Center officials, the new David Geffen Hall is the home of the New York Philharmonic Orchestra. Pulp Studio’s polished and carefully etched bent railing and guardrails complement the elegant intimacy of the new performing arts center, and helped it win this year’s “Best Glass Interior” award. “These are the most beautiful railings I’ve ever seen,” says Glass Magazine Awards judge Martin Bracamonte, vice

president of marketing and innovation, Vitro Architectural Glass. “A brilliant and elegant use of glass.”

The fabricator created over 8,700 square feet of flat and bent laminated glass railings and guardrails. Pulp Studio solved the problem of bending glass for the tight, 8-inch radii specified for the project through its chemical strengthening process. “Pulp Studio’s chemically strengthened glass is stronger, more durable and more versatile than traditional thermal bending,” explains Kirk

Johnson, COO, Pulp Studio. Using the process, the fabricator bent the glass without undermining the strength of the glass itself.

Guardrail glass used specially etched low-iron laminated glass, finished with a digital design for enhanced privacy and intimacy. Using its Precision Edge technology, the fabricator also applied post-polish to the glass edgework, completing the refined look. “The exposed edges on glass handrails are an aesthetic detail that shouldn’t be overlooked,”

says Johnson. “Codes only require that handrail glass be laminated, but high-quality edgework is imperative for the integrity of the design.”

Judges praised the impressive technical feat of bending glass and the aesthetic achievement. “Normally, a handrail is an afterthought whereas the aesthetics of the acid etch handrail make the glass a focal point,” says Glass Magazine Awards judge Jacob Kasbrick, commercial segment and technical services manager, Guardian Glass





Nominating Company
Pulp Studio

Location
New York City

Winning Team
ARCHITECTS: Tod Williams Billie Tsien Architects; Diamond Schmitt
CONTRACT GLAZIER: Lafayette Metal & Glass Co. in Hauppauge, NY
GLASS FABRICATOR: Pulp Studio
ACOUSTIC DESIGN: Akustiks LLC
PHOTO CREDIT: Michael Moran/OTTO

THE JUDGES

The project awards would not be possible without the expertise of our judges, who come from every part of the glass industry. The Glass Magazine editorial team again thanks them for taking the time to share their insights with us.



Jessie Robertson
Marketing Manager,
Steel Encounters



Diana San Diego
Vice President of
Marketing, Safti First



Julie Schimmelpenningh
Global Applications
Manager, Eastman
Chemical Co.



Mary Avery
Vice President of
Marketing, Tubelite



Ricardo Dominguez
President, Jordon Glass
Machinery



Sara Barchak
Marketing
Communications
Manager, EFCO Corp.



Jennifer Highfield
Architectural Design
Associate, Viracon



Martin Bracamonte
Vice President
of Marketing and
Innovation, Vitro
Architectural Glass



Jacob Kasbrick
Guardian Glass
Commercial Segment
and Technical Services
Manager, Guardian
Industries



Tammy Schroeder
Director of Marketing,
Linetec



Tara Brummet
Chief of Staff, Vitrum
Glass, Apex Aluminum
& Lorval Developments



Nataline A. Lomedico
CEO and President,
Giroux Glass Inc.



Stephen Selkowitz
Affiliate, Lawrence
Berkeley National
Laboratory



Peter de Gorter
Vice President,
DeGorter Inc.



Kayla Natividad
Architectural Technical
Services Engineer, NSG
Pilkington



Syndi Sim
Vice President of
Marketing and Business
Development, Diamon-
Fusion International



Alice Dickerson
Founder and Managing
Director, Division 08
Marketing



Tom O'Malley
Founding partner
and Director of Sales,
Clover Architectural
Products



John R. Stephenson
Senior Architect, BRPH

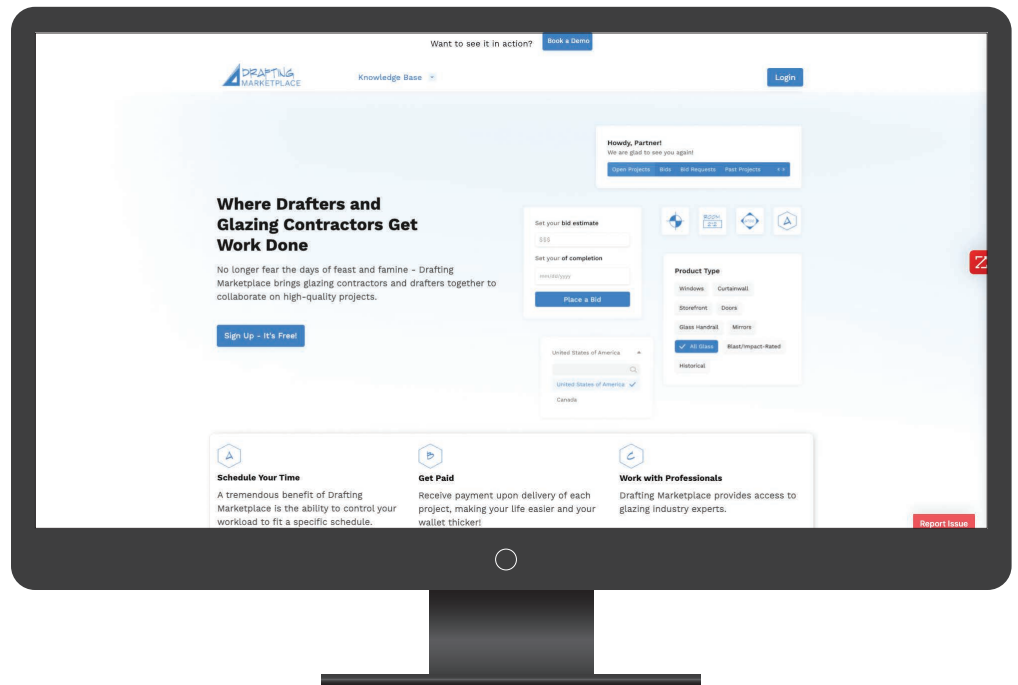

THE PRODUCTS

► R&D AWARD

DRAFTINGMARKETPLACE.COM

BY DRAFTINGMARKETPLACE.COM

This year's "R&D Award" winner has a unique origin story. Brandon Bellegarde combined his software and marketing expertise with the 20 years of drafting experience of his life-long friend Tyler Faulk to create DraftingMarketPlace.com. The online platform is designed to make sourcing quality shop drawings faster and easier.

The platform was created in response to Faulk's frustrations with the daily challenges of being a drafter in the glass industry. To provide better tools, the pair sat down with their team to prioritize the

challenges they wanted to solve. "We then began developing programmatic solutions, using the minimum viable product and scrum approach to software development," say Bellegarde and Faulk. "Once the base product was developed, we began the beta test phase that lasted around two years."

To use the tool, glazing contractors post projects—containing quotes, architectural drawings, hardware schedules and other information—on the platform. Then drafters bid for the opportunity to complete

the shop drawings. As glazing contractors receive bids for their projects, they individually review each drafter and their bid to determine the drafter or drafting company best suited for the project.

They continued to beta test the platform with drafters and glazing contractors across the country, until they released it to the public at Glassbuild 2022. "We conducted interviews, collected feedback and modified designs along the way until we had a product we were comfortable releasing to market," they say.

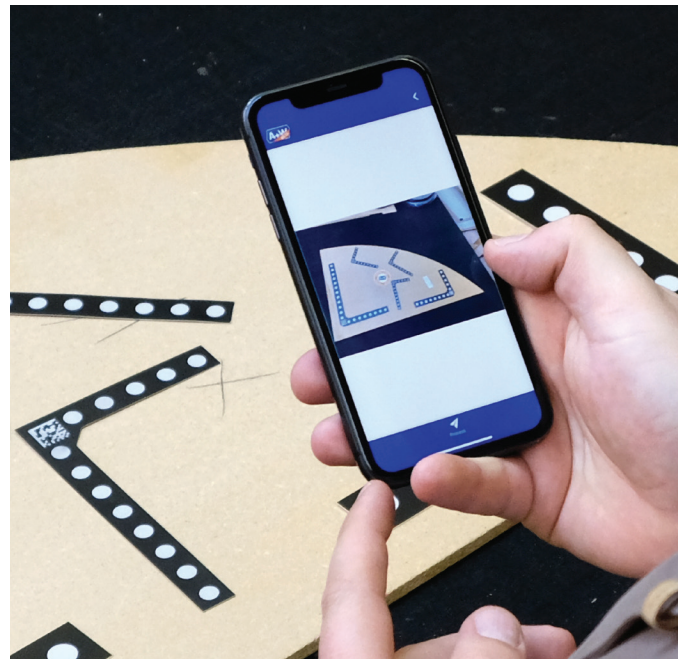

Photo by Michael Kuettner

▼
**BEST
 INNOVATION
 FOR THE
 FACTORY**

A+W iSHAPE

BY A+W SOFTWARE

▼
S

peed is highly valued, especially now as supply chain delays lengthen lead times. A+W Software's iShape application, this year's "Best Innovation for the Factory" winner, aims to speed up the templating process with a template-digitizing software solution.

Glass fabricators can find it time-consuming and difficult to accurately and efficiently convert regularly supplied templates to cut glass, says Chris Kammer, marketing lead, A+W Software. The iShape app, which uses Viprotron technology, allows glass fabricators to photograph customer templates with their smartphone camera. iShape accurately assesses finite radiuses and subtle shape variations on a given template with custom QR-coded L-angles that assist the software in shape reference, says Kammer.

"Even your customers and staff can photograph templates on-site, reducing travel and service times," says Kammer.

The iShape app analyzes the template image and provides a confidence factor to achieve the desired tolerance on the shape within 1 millimeter. The processing power of A+W's cloud backend gives customers a digital twin of their templates to smooth out unintended imperfections.

The app supports Android and iOS devices with modern camera configurations. The company can guarantee an accuracy of 1 centimeter per square meter to the template size, and provides hints for the user in the digitalization process.



▼
**BEST HARDWARE
PRODUCT OR SYSTEM**

OCULA FRAMELESS WINDSCREEN

BY SIGHTLINE COMMERCIAL
SOLUTIONS

In Sightline Commercial Solutions' Ocula Frameless Windscreen, this year's winner for "Best Hardware Product or System," hardware is minimal but crucial. Manufacturers designed this glass windscreen system to be post-free. "Unlike traditional glass windscreens that require installers to lift large panes of glass and slide them in from the top of the post system, Ocula glass panels are mounted with baseplates and an escutcheon cover," says Jon Chase, vice president of engineering and marketing, Sightline Commercial Solutions. This helps to reduce installation time and reduce costs, he says.

Chase says the system responds to the "all things al fresco" trend—i.e., incorporating outdoor areas into hospitality, health care and high-rise projects. "It makes outdoor areas

more useful and allows architects to create open, airy environments without sacrificing the very thing that draws people outside in the first place—the views."

To provide these unobstructed outdoor views while still protecting occupants from wind and rain, manufacturers minimized metal members of the system. "This post-free design created localized stress on the glass panels, requiring a thorough finite element analysis review to confirm the product would safely withstand various applications and structural considerations, such as live loads, seismic actions and wind loading," says Chase.

Sightline's Ocula can withstand wind loads up to 86 pounds per square inch at a guardrail height of 43 inches.

A+W Software

for Glass, Windows & Doors

Scanning Takes a Giant Leap Forward

A+W Smart Companion's revolutionary scanning app is an info terminal running on smart devices with greater computing power and outstanding graphics. This app benefits users, saving time and money, by making processes quicker and mobile.

Learn more about A+W's intelligently designed A+W Smart Companion app for flat glass, window, and door fabricators.

www.a-w.com/us



A+W Smart Companion serves as your scanning device moving items from station to station; it also:

1

Works as a mobile info terminal

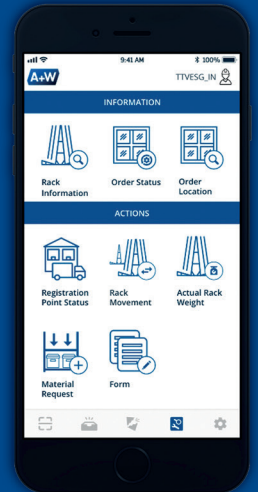

2

Securely and accurately scans barcodes individually or in continuous mode

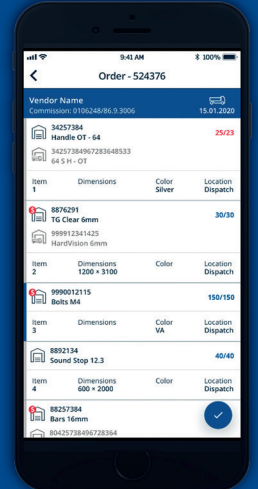

3

Increases employee productivity by displaying critical information, while also sending and receiving data to your ERP



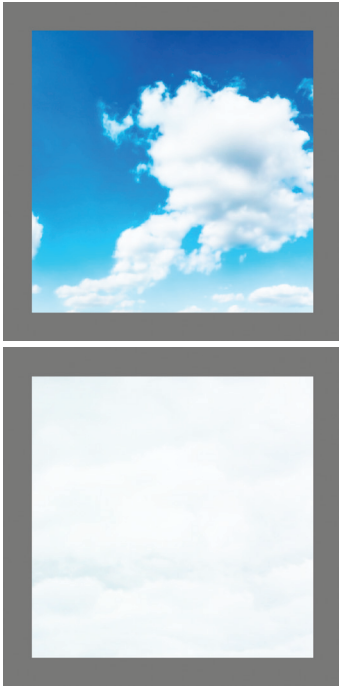

► BEST GLASS OR GLASS COMPONENT

SUNGUARD SUPERNEUTRAL SNR 35

BY GUARDIAN GLASS



Guardian Glass' SunGuard SuperNeutral SNR 35 coated glass, this year's winner for "Best Glass or Glass Component," combines aesthetics and performance, the pinnacle of achievement for any new architectural glass.

SNR 35 provides architects with a classical, neutral silver aesthetic, both at normal and angular incidence, with excellent energy performance led by a low solar heat gain coefficient of 0.17. The result is an architectural glass designed

to allow attractive building exteriors and bright, comfortable interiors.

Developed at the same time as the company's SNR 50 glass (last year's winner in this category), the glass manufacturer sought architect input at multiple stages. The development team shared glass samples with architects for feedback. "With multiple mock-up viewings, the research and development team and plant team were able to tweak the product to deliver the broadest

market appeal," says Jacob Kasbrick, commercial segment and technical services manager, Guardian Glass.

The SNR 35 coating is designed for the No. 2 surface of a standard insulating glass unit. This coating can be paired with various substrates at the following thicknesses: 5-millimeter to 12-mm, Clear and UltraClear low-iron glass; and 6-mm to 10-mm, Green and CrystalGray glass. The product is available in jumbo sizes as well.

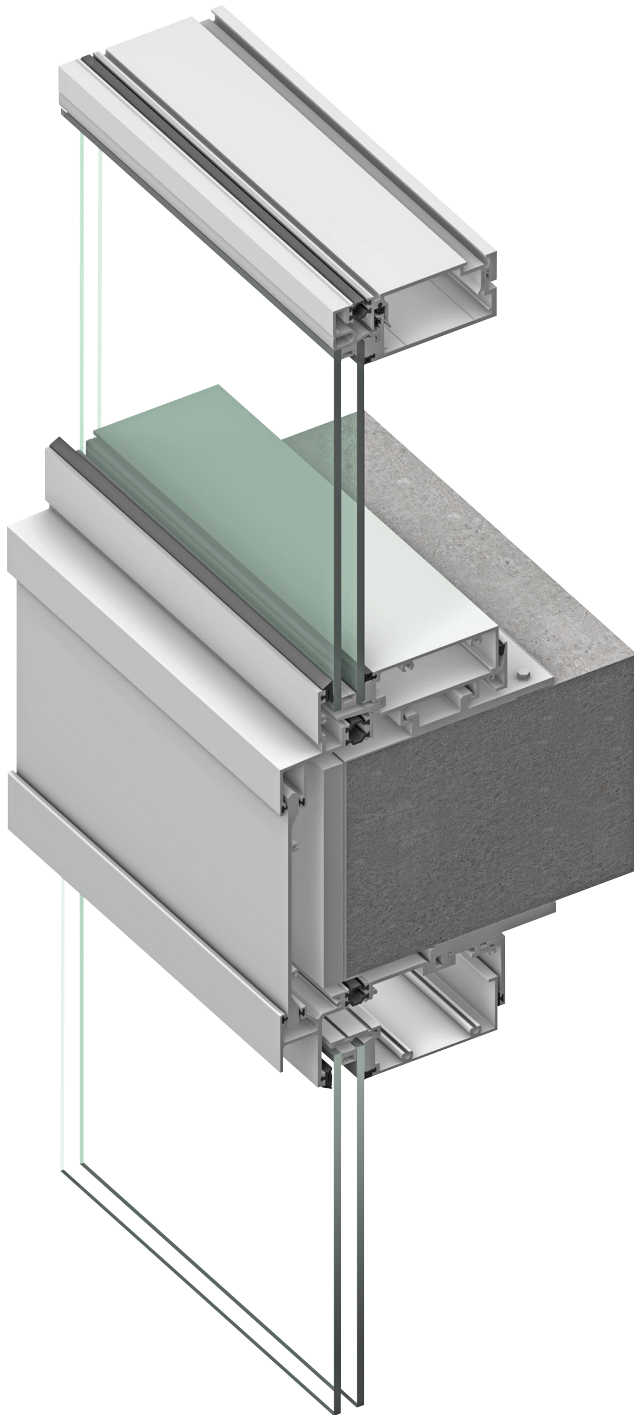

▼
**BEST FRAMING
SYSTEM OR
COMPONENT**

950SG SERIES THERM-BLOCK WINDOW WALL SYSTEM

BY TUBELITE



Tubelite describes its 950SG Series Therm-Block Window Wall system as providing “the look of curtain wall with the economy of slab-to-slab framing in mid- to high-rise commercial buildings.” This year’s winner for “Best Framing System or Component,” the product offers a four-side, structural sealant glazed window wall that provides a thermally broken, aluminum framing solution for between-slab horizontal spans on commercial buildings.

Beyond aesthetics, the 950SG offers performance criteria: a U-factor of up to 0.33 and a frame condensation resistance factor of 82 per AAMA 1503. The system also meets acoustic, air, water and structural performance standards.

Tubelite’s new window wall also aims to reduce installation time. With fewer parts and steps, the systems are installed entirely from the building’s interior. A vertical, extruded silicone gasket eliminates the need for an exterior-applied wet seal, and a single-piece, anti-buckling clip simplifies installation.



► INNOVATION FOR INSTALLERS

ACHIEVE FGR FRAMELESS GLASS RAILING SYSTEMS

BY FRAMELESS HARDWARE CO.



FHC's new Achieve FGR frameless glass railing systems significantly streamline the installation process, making it an understandable win for this year's "Best Innovation for Installers." The dry attachment system avoids traditional expansion cement, and allows for adjustment and easy removal, say officials.



Installation involves the

company's "One Seal" 1SGA gasket, which field workers can pre-load before setting glass. They can then use the same gasket on the inside to finish the installation, allowing installers to stock fewer SKUs. Further speeding installation, the system is 40% lighter than a traditional base shoe.

Achieve was also designed to optimize and reduce stress

on monolithic and laminated tempered glass and can accommodate heavy glass railing and windscreen applications. Custom fabrication is possible, and the product is available in 10- and 20-foot options, drilled or undrilled. Achieve is compatible with 1/2-inch tempered monolithic, and 9/16-inch, 11/16-inch and 13/16-inch tempered laminated glass. ■

THINK BIG
THINK GLASSWERKS™

Southern California's
Premier Fabricator of
Residential & Architectural Glass
8600 Rheem Ave, Southgate, CA 90280
glasswerks.com

**Insulated
Glass Doors**
Residential &
Architectural



Insulated glass shown on FHC ASPIRE doors.

Commercial Entrances & Doors

- All-Glass Entrance Systems
- Bottom Rolling Door Systems
- Panic Doors & Devices
- Stacking Sliding Doors
- Patch Railing Systems
- Custom Hardware

Custom Fabrication

- Up to 3/4" Monolithic Glass
- Laminated Glass
- Miters, Bevels, Holes, & Notching
- Digital Images & Silk screening
- Patch Railing Systems
- Custom Hardware



For more information, contact us at **888.789.7810** or visit us at glasswerks.com



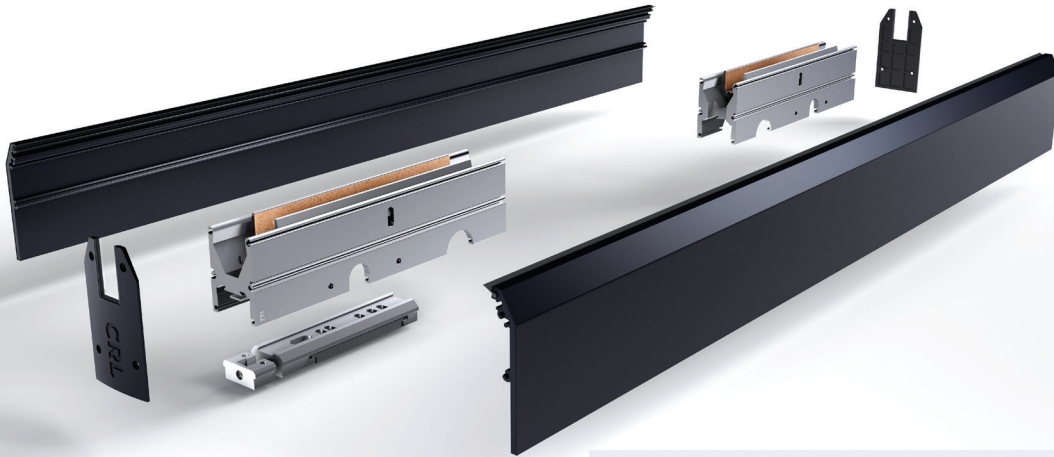

The CRL DRX™ Modular Door Rail System comprises independent parts, including rail bodies, adjustable slide block, side covers, gasket and end caps. DRX component parts can be attached to the glass as soon as it's fabricated to eliminate lead times on custom doors. Photos courtesy of CRL.

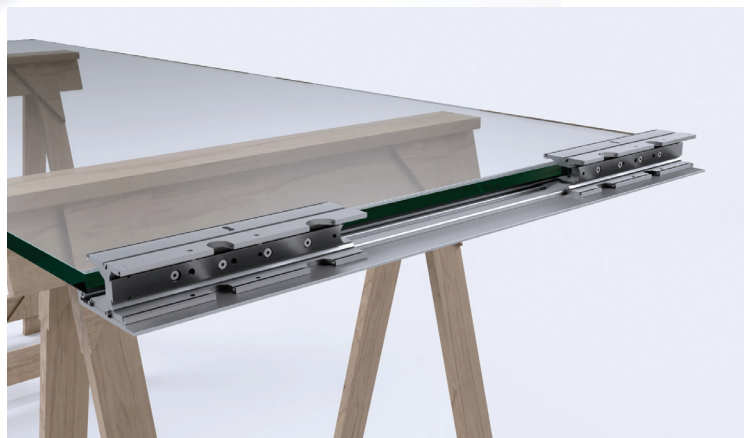

INNOVATION BOOSTED BY VIGOROUS TESTING

IN-HOUSE PRODUCT TESTING MOVES THE NEEDLE TOWARD MODULAR SOLUTIONS

BY TARA LUKASIK
MANAGING EDITOR

A vital component of the innovation process, in-house product testing helps companies enhance product quality, iterate on designs, streamline development cycles, protect intellectual property and foster a culture of invention. The insights gained can be leveraged to help continuously improve a company's products and deliver innovative solutions to meet customer needs.

CRL is a leading provider of architectural metals, glass fittings and professional-grade glazing supplies required by professional glaziers and glass shops to complete the installation of architectural glass in both commercial and residential markets. With a reputation for quality

and expertise, the company's innovative designs, subjected to rigorous in-house product testing and certification, offer modern aesthetics to the glazing and architectural hardware industries, as well as new approaches to product design that address the industry's need to complete projects on ever-shortening timelines.

In June, I was able to sit down with Mark Suehiro, technical director, architectural hardware, at CRL to discuss the company's process to identifying areas for innovation, its in-house design testing, and some of the leading product trends they're seeing, including a move to modular solutions to address tight installation timeframes.

Here are some highlights of my conversation with Suehiro.

As both a designer and manufacturer of products, what is the company's process to identifying areas for innovation?

CRL's approach is based on listening. We go to great lengths to understand the challenges, large and small, that our glazing partners and their customers are dealing with. Sometimes the issues are business related, such as the need to increase efficiencies or meet ever-shortening installation deadlines. Sometimes the issues are technical and product focused. Occasionally, these issues are combined, requiring an approach that solves a business issue through a completely new product or design approach.

Tell us about the role of design and testing in the innovation process.

We don't outsource the design process. It's critical that our in-house staff—engineers and designers—collaborate with our product, sales and manufacturing teams. This enables us to maintain a laser focus on the problem throughout the design phase, ensuring the solution is usable, while accounting for manufacturing considerations that make the solution viable in the marketplace.

We also insist on handle testing in-house, with nearly 4,000 square feet of space in our [Los Angeles, California] facility dedicated to putting our products through their paces. The real world is an unforgiving crucible for testing the operation and durability of mechanical parts. There is simply no technical or theoretical substitute for thorough, real-world testing of new innovations.

What part does customer feedback from contractors and installers play in the innovation product testing process?

CRL constantly seeks input from glaziers as well as the architects, interior designers and building owners

they serve, to assess current needs and to evaluate how our solutions address those needs. We also monitor feedback from our customers, and our expert contractors and installers. Their feedback is critical as it emphasizes real-world applications. Glazier and customer feedback informs all of our solutions, making them more usable and more valuable.

Let's talk trends. What are the leading product trends you're seeing in the industry? How is CRL innovating to meet these changing needs?

Labor issues continue to plague the glazing industry. Our glazing customers simply can't find enough qualified, skilled professionals to fill their ranks. We are constantly researching and considering process and product improvements that will address issues precipitated by the shortage of skilled labor, which is compounded by ongoing, industry-wide supply chain and inventory bottlenecks that cause project delays.

Other trends deal with products that help speed up the installation process, whether it's unitized systems or modular systems that cut down on lead times.

We're seeing a trend toward product modularization. Can you speak to how this is affecting your customers?

Recently, glazers have begun dealing with a different business problem—extended fabrication timeframes for custom commercial glass doors, which delays installations. Waiting for the manufacture of custom doors or even unitized products—prefabricated products like curtain walls that are manufactured in a controlled factory environment, then shipped to the job site as pre-glazed units ready for installation—can put entire projects behind schedule. A new approach

to the product—a modular approach—was the innovation needed to address this business problem.

The new CRL DRX Modular Door Rail System deconstructs a standard door rail into independent parts giving glass temperers and glazing contractors greater control over when, where and how door rails are installed, adjusted and updated. Unlike standard door rails, the DRX system features independent side covers and end caps that can be easily installed or replaced without having to remove the door from the pivot. The system also features 10 1/2-inch-length rail bodies that can be moved along the glass to accommodate standard or custom door lengths. Because of this, they can be stocked to virtually eliminate lead times for installing custom glass doors.

What part does in-house product testing play in maintaining quality and determining the lifespan of your products?

Testing plays a central role in new product development. We make sure our products are up to code and meet or exceed industry testing standards by staying on top of industry developments and applying the latest testing equipment. Each new product—including our latest innovation, the CRL DRX Modular Door Rail—benefits from rigorous testing and strenuous protocols. The DRX has been tested to 500,000 cycles to ensure lasting durability, and it features a superior glass clamping force, able to withstand a pull force test of 1,300 pounds.

This really sets us apart because we focus not only on meeting current customer challenges but anticipating future challenges that may arise through changing industry dynamics. ■

SPONSORED CONTENT



PRODUCTS



SOLUTION: SOLID B HINGE

Aluminum profiles have grown in popularity in the commercial sector, and so has the need for hardware aesthetically and functionally compatible with this trend.

Roto designed the Solid B butt hinges for hinged aluminum doors to fit this need. The Solid B line consists of two- and three-part clampable butt hinges that can accommodate aluminum doors up to 265 and 352 pounds. The hinge fixing can be adapted to match the profile groove, making the Solid B hinge extremely versatile. Our load-bearing components are also made from extruded aluminum

for greater stability and dependability.

The slim, 24-millimeter (0.94-inch) diameter design allows the hinges to integrate seamlessly into aluminum doors, adhering to the modern aesthetic of the aluminum profile trend. The hinge also stays in vertical parallel alignment after adjustment. A wide range of colors and different coating methods, including custom coating, grant greater design freedom.

Installation of these hinges is fast and straightforward thanks to the preassembled clamping blocks on the sash hinge and clamping plate on the frame hinge. The high-

quality self-lubricating vinyl brushing also allows for easy maintenance, making the Solid B hinges simple, reliable and durable while maintaining the slim, modern aesthetic of the aluminum sector.

Learn more at rotonorthamerica.com, 800/243-0893. ■

SPONSORED CONTENT



KEY FEATURES

ACCOMMODATES ALUMINUM DOORS UP TO 352 POUNDS

SLIM BUTT HINGE DESIGN WITH A DIAMETER OF 24 MM

INTEGRATED ADJUSTMENT MECHANISMS IN THE ROLLER

PRE-ASSEMBLED CLAMPING BLOCK ALLOWS QUICK INSTALLATION

SUITABLE FOR INWARD AND OUTWARD OPENING DOORS



01



02

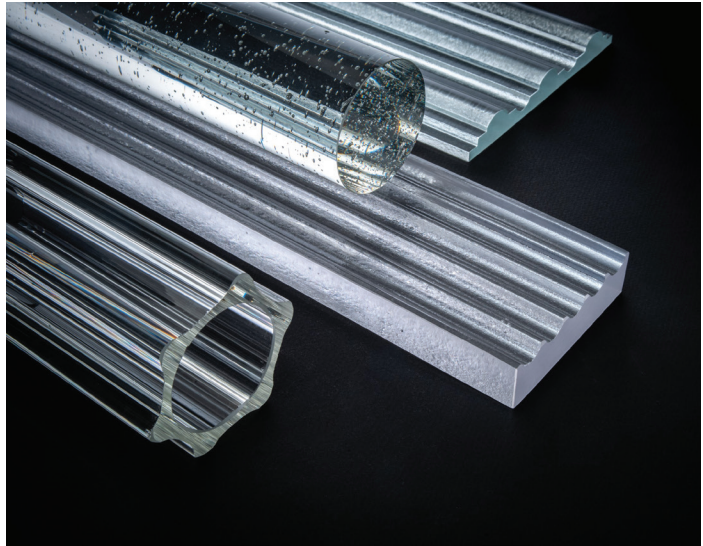

03

01. Insulating glass

The latest generation of SANCO Phon insulating glass offers appropriate solutions for the various noise protection zones surrounding airports and noticeably improves the quality of living spaces. In addition to providing thermal insulation, the glass reduces noise pollution by 42 decibels.

+{49} 0731-4096-147 | SANCO.DE

02. Glass sample kit

Vitro Architectural Glass introduced a new Advanced Low-Emissivity Glass Sample Kit featuring Vitro’s range of Solarban solar control, low-e glass products for comparison. Each product sample in the sample kit features a solar heat gain coefficient of 0.25 or less and is designed to reduce the transmittance of heat energy from the sun. Applications include façade designs requiring daylighting control.

412/820-8500 | VITROGLAZINGS.COM

03. Glass moldings

These architectural cast glass moldings by Jockimo can help create a decorative focal point in any high-end interior, like in a window display at a boutique or framing a fireplace in the lobby of a hotel. There are six pre-designed, standard molding options. These standard offerings can also be fully customized, or customers can start from scratch and choose shape, size, color and finish.

949/251-0075 | JOCKIMO.COM

PRODUCTS



01

01. Robotic line

A new Lattuada-Knittel robotic solution offers one polisher and one robot on a track. This line is for customers who want to increase the automation level of their edging department. Before loading the glass, this device can check the position of the edge for safe and smooth loading. The line can be operated by an operator who only must load a rack and start the line. After that, all glasses will be automatically ground on four sides.

+(39) 0331-8327-13 | ADELIOLATTUADA.COM



02



03

03. Stationary louvers

Louver type K604 featuring a 4-inch frame depth and louver type K606 featuring a 6-inch frame depth are extruded aluminum stationary louvers by Airlite. These are ideal for applications requiring intake and exhaust ventilation with moderate protection against water penetration. Their design incorporates non-drainable blades, sloped sill and hidden vertical mullions when configured as multiple sections. A variety of options, accessories and architectural finishes are available.

715/841-8757 | AIROLITE.COM

Combined Expertise for Customized Solutions

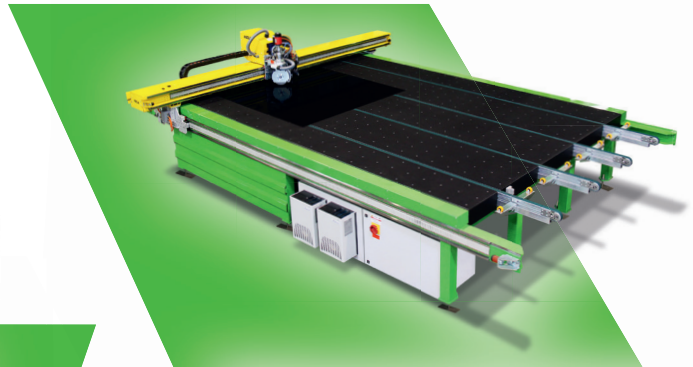
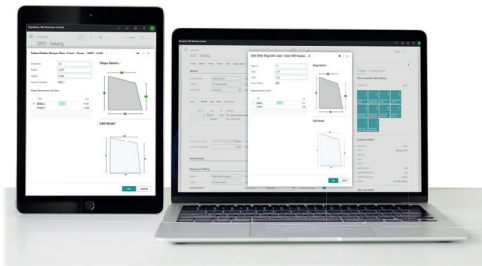

Developing the Value Chain with HEGLA Group

With machines and integrated systems from HEGLA, you can achieve maximum precision, quality and automation. Efficient software solutions from HEGLA-HANIC optimize your production control and planning. Innovations such as laser-assisted finishings for birdfriendly glass, antibacterial glass or better cell reception further increase your added value.



Suppliers Guide

ARCHITECTURAL FINISHES

POWDER COATING



Frameless Hardware Company **NGA ADV**
4361 Firestone Blvd.
South Gate, CA 90280
US: 888/295-4531
Phone: 323/968-2031
Fax: 323/336-8307
E-mail: info@fhc-usa.com
www.fhc-usa.com

ARCHITECTURAL GLASS/FLAT GLASS

GENERAL



American Insulated Glass **ADV**
7 Regional Fabrication
Locations in the US
US: 866/519-1565
Phone: 404/361-9154
E-mail: sales@aiglass.com
Web: www.aiglass.com



Benowitz International Glass Products, LLC
"The Pinnacle of Innovation"
Phone: 702/885-4772
E-mail: sales@benowitzinternationalglass.com
www.benowitzinternationalglass.com



GGI **NGA ADV**
101 Venture Way
Secaucus, NJ 07094
US: 800/431-2042
Phone: 201/553-1850
Fax: 201/553-1851
E-mail: sales@generalglass.com
www.generalglass.com



Glassfab Tempering Services **ADV**
1448 Mariani Ct.
Tracy, CA 95304
US: 800/490-3860
Phone: 209/229-1060
Fax: 209/229-1061
E-mail: info@glassfabUSA.com
www.glassfabUSA.com



Isoclima
Specialty Glass, LLC
Global Security Glazing
1400 Grandview Ave.
PO Box 739
East Butler, PA
E-mail: sales@isoclimasg.com
U.S.: 866/412-6977
www.isoclimasg.com
www.security-glazing.com



McGRORYGLASS

McGrory Glass Inc.
1400 Grandview Ave.
Paulsboro, NJ 08066
Phone: 800/220-3749
Fax: 856/579-3233
E-mail: sales@mcgrory.com
www.mcgrory.com



Oldcastle BuildingEnvelope®
More Than 85 Manufacturing and
Distribution Locations in 25 US
States, 4 Canadian Provinces, 3
European Countries and 3
Australian States. **ADV NGA**
US: 866-OLDCASTLE
(653-2278)
www.obe.com

ANTI-REFLECTIVE



GGI **NGA ADV**
101 Venture Way
Secaucus, NJ 07094
US: 800/431-2042
Phone: 201/553-1850
Fax: 201/553-1851
E-mail: sales@generalglass.com
www.generalglass.com

McGrory Glass Inc.
1400 Grandview Ave.
Paulsboro, NJ 08066
Phone: 800/220-3749
Fax: 856/579-3233
E-mail: sales@mcgrory.com
www.mcgrory.com

BENT

Go to category **BENT GLASS**

BLAST RESISTANT



RAY-BAR USA **NGA**
Security, Ballistic Glass
and IGU's
US: 800/444-9729
Fax: 800/333-9729
E-mail: sales@raybar.com
www.raybar.com



SAFTI FIRST™ Fire Rated Glazing **ADV NGA**
100 N. Hill Dr., Ste. 12
Brisbane, CA 94005-1010
US: 888/653-3333
Phone: 415/824-4900
Fax: 415/824-5900
E-mail: info@safti.com
www.safti.com

Vetrotech Saint-Gobain Fire-Rated Glass and Framing **ADV NGA**
2108 B St. NW, Ste. 110
Auburn, WA 98001
Phone: 888/803-9533
E-mail: vetrotech.sales@saint-gobain.com
www.vetrotechusa.com

BULLET RESISTANT

McGrory Glass Inc.
1400 Grandview Ave.
Paulsboro, NJ 08066
Phone: 800/220-3749
Fax: 856/579-3233
E-mail: sales@mcgrory.com
www.mcgrory.com



RAY-BAR USA **NGA**
Security, Ballistic Glass
and IGU's
US: 800/444-9729
Fax: 800/333-9729
E-mail: sales@raybar.com
www.raybar.com



Riot Glass LLC **ADV**
17941 Brookshire Ln.
Huntington Beach, CA 92647
US: 800/580-2303
Phone: 714/904-1030
E-mail: brad@riotglass.com
www.riotglass.com

Vetrotech Saint-Gobain Fire-Rated Glass and Framing **ADV NGA**
2108 B St. NW, Ste. 110
Auburn, WA 98001
Phone: 888/803-9533
E-mail: vetrotech.sales@saint-gobain.com
www.vetrotechusa.com

Oldcastle BuildingEnvelope®
More Than 85 Manufacturing and
Distribution Locations in 25 US
States, 4 Canadian Provinces, 3
European Countries and 3
Australian States. **ADV NGA**
US: 866-OLDCASTLE
(653-2278)
www.obe.com



SAFTI FIRST™ Fire Rated Glazing **ADV NGA**
100 N. Hill Dr., Ste. 12
Brisbane, CA 94005-1010
US: 888/653-3333
Phone: 415/824-4900
Fax: 415/824-5900
E-mail: info@safti.com
www.safti.com



Technical Glass Products **NGA**
8107 Bracken Place SE
Snoqualmie, WA 98065
Phone: 800/426-0279
Fax: 425/396-8300
E-mail: sales@fireglass.com
www.fireglass.com

BURGLARY RESISTANT

McGrory Glass Inc.
1400 Grandview Ave.
Paulsboro, NJ 08066
Phone: 800/220-3749
Fax: 856/579-3233
E-mail: sales@mcgrory.com
www.mcgrory.com



RAY-BAR USA **NGA**
Security, Ballistic Glass
and IGU's
US: 800/444-9729
Fax: 800/333-9729
E-mail: sales@raybar.com
www.raybar.com

Oldcastle BuildingEnvelope®
More Than 85 Manufacturing and
Distribution Locations in 25 US
States, 4 Canadian Provinces, 3
European Countries and 3
Australian States. **ADV NGA**
US: 866-OLDCASTLE
(653-2278)
www.obe.com

CHEMICALLY STRENGTHENED



Precision Glass Bending Corp. **ADV NGA**
P.O. Box 1970
3811 Hwy. 10 West
Greenwood, AR 72936-1970
US: 800/543-8796
Phone: 479/996-8065
Fax: 800/543-8798
E-mail: sales@e-bentglass.com
www.e-bentglass.com
(See our ad on page 81)

COLOR COATED

McGrory Glass Inc.
1400 Grandview Ave.
Paulsboro, NJ 08066
Phone: 800/220-3749
Fax: 856/579-3233
E-mail: sales@mcgrory.com
www.mcgrory.com

DECORATIVE

Go to category
DECORATIVE GLASS

DISTRIBUTORS



American Insulated Glass **ADV**
7 Regional Fabrication
Locations in the US
US: 866/519-1565
Phone: 404/361-9154
E-mail: sales@aiglass.com
Web: www.aiglass.com



GGI **NGA ADV**
101 Venture Way
Secaucus, NJ 07094
US: 800/431-2042
Phone: 201/553-1850
Fax: 201/553-1851
E-mail: sales@generalglass.com
www.generalglass.com

SGC International Inc.
6489 Corvette Street
Commerce, CA 90004
US: 866/802-8682
Phone: 323/318-2998
Fax: 323/318-2999
E-mail: sgccjames@yahoo.com;
hennysgc@gmail.com
www.sgc-usa.com
(See our ad on page 79)

FIRE-RATED



American Insulated Glass **ADV**
7 Regional Fabrication
Locations in the US
US: 866/519-1565
Phone: 404/361-9154
E-mail: sales@aiglass.com
Web: www.aiglass.com



GGI **NGA ADV**
101 Venture Way
Secaucus, NJ 07094
US: 800/431-2042
Phone: 201/553-1850
Fax: 201/553-1851
E-mail: sales@generalglass.com
www.generalglass.com



Glassopolis
We Put Glass Contractors First
Fast Quotes. Fast Delivery
Phone: 800/262-9600
Fax: 800/872-9601
E-mail: sales@glassopolis.com
www.glassopolis.com



McGrory Glass Inc.
1400 Grandview Ave.
Paulsboro, NJ 08066
Phone: 800/220-3749
Fax: 856/579-3233
E-mail: sales@mcgrory.com
www.mcgrory.com



RAY-BAR USA **NGA**
Fastest Fire Glass and
IGU's Available
Phone: 800/444-9729
Fax: 800/333-9729
E-mail: sales@raybar.com
www.FireProofGlass.com



SAFTI FIRST™ Fire Rated Glazing
100 N. Hill Dr., Ste. 12
Brisbane, CA 94005-1010
US: 888/653-3333
Phone: 415/824-4900
Fax: 415/824-5900
E-mail: info@safiti.com
www.safiti.com



Technical Glass Products
8107 Bracken Place SE
Snoqualmie, WA 98065
Phone: 800/426-0279
Fax: 425/396-8300
E-mail: sales@fireglass.com
www.fireglass.com

Vetrotech Saint-Gobain Fire-Rated Glass and Framing
2108 B St. NW, Ste. 110
Auburn, WA 98001
Phone: 888/803-9533
E-mail: vetrotech.sales@saint-gobain.com
www.vetrotechusa.com

**FIRE-RATED:
IMPACT RESISTANT**

McGrory Glass Inc.
1400 Grandview Ave.
Paulsboro, NJ 08066
Phone: 800/220-3749
Fax: 856/579-3233
E-mail: sales@mcgrory.com
www.mcgrory.com



Glassopolis
We Put Glass Contractors First
Fast Quotes. Fast Delivery
Phone: 800/262-9600
Fax: 800/872-9601
E-mail: sales@glassopolis.com
www.glassopolis.com



RAY-BAR USA
Fastest Fire Glass and
IGU's Available
Phone: 800/444-9729
Fax: 800/333-9729
E-mail: sales@raybar.com
www.FireProofGlass.com



SAFTI FIRST™ Fire Rated Glazing
100 N. Hill Dr., Ste. 12
Brisbane, CA 94005-1010
US: 888/653-3333
Phone: 415/824-4900
Fax: 415/824-5900
E-mail: info@safiti.com
www.safiti.com



Technical Glass Products
8107 Bracken Place SE
Snoqualmie, WA 98065
Phone: 800/426-0279
Fax: 425/396-8300
E-mail: sales@fireglass.com
www.fireglass.com

FLOORS

McGrory Glass Inc.
1400 Grandview Ave.
Paulsboro, NJ 08066
Phone: 800/220-3749
Fax: 856/579-3233
E-mail: sales@mcgrory.com
www.mcgrory.com



SAFTI FIRST™ Fire Rated Glazing
100 N. Hill Dr., Ste. 12
Brisbane, CA 94005-1010
US: 888/653-3333
Phone: 415/824-4900
Fax: 415/824-5900
E-mail: info@safiti.com
www.safiti.com

**GLARE REDUCING,
FINISHED**

McGrory Glass Inc.
1400 Grandview Ave.
Paulsboro, NJ 08066
Phone: 800/220-3749
Fax: 856/579-3233
E-mail: sales@mcgrory.com
www.mcgrory.com

HANDRAILS

McGrory Glass Inc.
1400 Grandview Ave.
Paulsboro, NJ 08066
Phone: 800/220-3749
Fax: 856/579-3233
E-mail: sales@mcgrory.com
www.mcgrory.com

Oldcastle BuildingEnvelope®
More Than 85 Manufacturing and
Distribution Locations in 25 US
States, 4 Canadian Provinces, 3
European Countries and 3
Australian States.
US: 866-OLDCASTLE
(653-2278)
www.obe.com

HEAT SOAKED



Glassfab Tempering Services
1448 Mariani Ct.
Tracy, CA 95304
US: 800/490-3860
Phone: 209/229-1060
Fax: 209/229-1061
E-mail: info@GlassfabUSA.com
www.GlassfabUSA.com

McGrory Glass Inc.
1400 Grandview Ave.
Paulsboro, NJ 08066
Phone: 800/220-3749
Fax: 856/579-3233
E-mail: sales@mcgrory.com
www.mcgrory.com

Oldcastle BuildingEnvelope®
More Than 85 Manufacturing and
Distribution Locations in 25 US
States, 4 Canadian Provinces, 3
European Countries and 3
Australian States.
US: 866-OLDCASTLE
(653-2278)
www.obe.com

Oldcastle BuildingEnvelope®
More Than 85 Manufacturing and
Distribution Locations in 25 US
States, 4 Canadian Provinces, 3
European Countries and 3
Australian States.
US: 866-OLDCASTLE
(653-2278)
www.obe.com

HEAT-STRENGTHENED



Glassfab Tempering Services
1448 Mariani Ct.
Tracy, CA 95304
US: 800/490-3860
Phone: 209/229-1060
Fax: 209/229-1061
E-mail: info@GlassfabUSA.com
www.GlassfabUSA.com

Oldcastle BuildingEnvelope®
More Than 85 Manufacturing and
Distribution Locations in 25 US
States, 4 Canadian Provinces, 3
European Countries and 3
Australian States.
US: 866-OLDCASTLE
(653-2278)
www.obe.com

INSULATING

*Go to category INSULATING
GLASS, PRODUCTS,
COMPONENTS & EQUIPMENT*

LAMINATED

*Go to category LAMINATED
GLASS & EQUIPMENT*

LEAD

Amerope Enterprises Inc.
150 Commerce Rd.
Boynton Beach, FL 33426
US: 800/327-3320
Phone: 561/737-7370
Fax: 561/737-3721
E-mail: claire@amerope.com
www.amerope.com



Glassopolis
We Put Glass Contractors First
Fast Quotes. Fast Delivery
Phone: 800/262-9600
Fax: 800/872-9601
E-mail: sales@glassopolis.com
www.glassopolis.com

McGrory Glass Inc.
1400 Grandview Ave.
Paulsboro, NJ 08066
Phone: 800/220-3749
Fax: 856/579-3233
E-mail: sales@mcgrory.com
www.mcgrory.com



RAY-BAR USA
Fastest X-Ray Glass
and IGU's Available
US: 800/444-XRAY
Fax: 800/333-XRAY
E-mail: sales@raybar.com
www.raybar.com

LOW-EMISSIVITY

Oldcastle BuildingEnvelope®
More Than 85 Manufacturing and
Distribution Locations in 25 US
States, 4 Canadian Provinces, 3
European Countries and 3
Australian States.
US: 866-OLDCASTLE
(653-2278)
www.obe.com

LOW IRON



American Insulated Glass
7 Regional Fabrication
Locations in the US
US: 866/519-1565
Phone: 404/361-9154
E-mail: sales@aiglass.com
Web: www.aiglass.com

Oldcastle BuildingEnvelope®
More Than 85 Manufacturing and
Distribution Locations in 25 US
States, 4 Canadian Provinces, 3
European Countries and 3
Australian States.
US: 866-OLDCASTLE
(653-2278)
www.obe.com

OVERSIZED



Glassfab Tempering Services
1448 Mariani Ct.
Tracy, CA 95304
US: 800/490-3860
Phone: 209/229-1060
Fax: 209/229-1061
E-mail: info@GlassfabUSA.com
www.GlassfabUSA.com

McGrory Glass Inc.
1400 Grandview Ave.
Paulsboro, NJ 08066
Phone: 800/220-3749
Fax: 856/579-3233
E-mail: sales@mcgrory.com
www.mcgrory.com

PATTERNED



American Insulated Glass
7 Regional Fabrication
Locations in the US
US: 866/519-1565
Phone: 404/361-9154
E-mail: sales@aiglass.com
Web: www.aiglass.com

McGrory Glass Inc.
1400 Grandview Ave.
Paulsboro, NJ 08066
Phone: 800/220-3749
Fax: 856/579-3233
E-mail: sales@mcgrory.com
www.mcgrory.com

Oldcastle BuildingEnvelope®
More Than 85 Manufacturing and
Distribution Locations in 25 US
States, 4 Canadian Provinces, 3
European Countries and 3
Australian States.
US: 866-OLDCASTLE
(653-2278)
www.obe.com



**WWW.SGC-USA.COM
GLASS DISTRIBUTION CENTER**

- Glass Products:**
- Clear Float Glass (1/16" - 1')
 - Tinted Float Glass (1/8" - 1/2")
 - Low iron clear glass (1/16" - 1")
 - Textured patterned Glass
 - Polished Wire Glass (UL Listed)
 - Laminated glass (Clear & White)
 - Tinted laminated glass
 - Copper free mirror (1/8", 3/16", 1/4")
 - Safety backing mirror (CAT II)
 - Antique mirror & Deco mirror
 - Satin etched glass
 - Pyrolytic low-e glass
 - Triple silver low-e glass
 - Tempered glass

**Your local glass warehouse and
business partner. Thousands of
cases of glass and mirrors in stock
and ready to ship on-demand.**

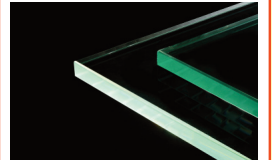

6489 Corvette Street • Commerce, CA 90040
email: sgciusa@gmail.com
1-866-802-8682 • 323-318-2998



GGI
101 Venture Way
Seaucus, NJ 07094
US: 800/431-2042
Phone: 201/553-1850
Fax: 201/553-1851
E-mail: sales@generalglass.com
www.generalglass.com

**POINT-SUPPORTED
SYSTEMS**

Oldcastle BuildingEnvelope®
More Than 85 Manufacturing and
Distribution Locations in 25 US
States, 4 Canadian Provinces, 3
European Countries and 3
Australian States.
US: 866-OLDCASTLE
(653-2278)
www.obe.com

**PRIVACY: ELECTRICALLY
SWITCHABLE**



American Switchglass
63 Via Pico Plaza, Ste 104
San Clemente, CA 92672
US: 800/838-6088
Phone: 949/254-6188
E-mail: sales@americanswitchglass.com
www.americanswitchglass.com

Suppliers Guide



ROCKWELL SHOWER DOOR HARDWARE



Heavy Duty Shower Hinges



Shower Door Pulls



Classic Shower Hinges

Tel: 510-270-5633
Fax: 309-276-2680
www.rockwellsecurityinc.com

McGrory Glass Inc.
1400 Grandview Ave.
Paulsboro, NJ 08066
Phone: 800/220-3749
Fax: 856/579-3233
E-mail: sales@mcgrory.com
www.mcgrory.com

SECURITY



McGrory Glass Inc.
1400 Grandview Ave.
Paulsboro, NJ 08066
Phone: 800/220-3749
Fax: 856/579-3233
E-mail: sales@mcgrory.com
www.mcgrory.com

RAY BAR

RAY-BAR USA
Security, Ballistic Glass and IGU's
US: 800/444-9729
Fax: 800/333-9729
E-mail: sales@raybar.com
www.raybar.com



RIOT GLASS
Riot Glass LLC
17941 Brookshire Ln.
Huntington Beach, CA 92647
US: 800/580-2303
Phone: 714/904-1030
E-mail: brad@riotglass.com
www.riotglass.com

SAFTI FIRST™ Fire Rated Glazing ADV NGA
100 N. Hill Dr., Ste. 12
Brisbane, CA 94005-1010
US: 888/653-3333
Phone: 415/824-4900
Fax: 415/824-5900
E-mail: info@saffi.com
www.saffi.com

SILKSCREENED



Glassfab Tempering Services ADV
1448 Mariani Ct.
Tracy, CA 95304
US: 800/490-3860
Phone: 209/229-1060
Fax: 209/229-1061
E-mail: info@glassfabusa.com
www.glassfabusa.com

Oldcastle BuildingEnvelope®
More Than 85 Manufacturing and Distribution Locations in 25 US States, 4 Canadian Provinces, 3 European Countries and 3 Australian States. ADV NGA
US: 866-OLDCASTLE (653-2278)
www.obe.com

SPANDREL



American Insulated Glass ADV
7 Regional Fabrication Locations in the US
US: 866/519-1565
Phone: 404/361-9154
E-mail: sales@aiglass.com
www.aiglass.com



GGI NGA ADV
101 Venture Way
Secaucus, NJ 07094
US: 800/431-2042
Phone: 201/553-1850
Fax: 201/553-1851
E-mail: sales@generalglass.com
www.generalglass.com

McGrory Glass Inc.
1400 Grandview Ave.
Paulsboro, NJ 08066
Phone: 800/220-3749
Fax: 856/579-3233
E-mail: sales@mcgrory.com
www.mcgrory.com

Oldcastle BuildingEnvelope®
More Than 85 Manufacturing and Distribution Locations in 25 US States, 4 Canadian Provinces, 3 European Countries and 3 Australian States. ADV NGA
US: 866-OLDCASTLE (653-2278)
www.obe.com



Prearco Inc. ADV
94 Cartier Blvd.
Riviere-du-Loup, GQ G5R 2M9
Canada
US: 800/463-1325
Phone: 418/862-2274
Fax: 418/862-8181
E-mail: sales@prearco.ca
www.prearco.ca

TEMPERED



American Insulated Glass ADV
7 Regional Fabrication Locations in the US
US: 866/519-1565
Phone: 404/361-9154
E-mail: sales@aiglass.com
www.aiglass.com



Glassfab Tempering Services ADV
1448 Mariani Ct.
Tracy, CA 95304
US: 800/490-3860
Phone: 209/229-1060
Fax: 209/229-1061
E-mail: info@glassfabusa.com
www.glassfabusa.com

McGrory Glass Inc.
1400 Grandview Ave.
Paulsboro, NJ 08066
Phone: 800/220-3749
Fax: 856/579-3233
E-mail: sales@mcgrory.com
www.mcgrory.com



Prearco Inc. ADV
94 Cartier Blvd.
Riviere-du-Loup, GQ G5R 2M9
Canada
US: 800/463-1325
Phone: 418/862-2274
Fax: 418/862-8181
E-mail: sales@prearco.ca
www.prearco.ca

Oldcastle BuildingEnvelope®
More Than 85 Manufacturing and Distribution Locations in 25 US States, 4 Canadian Provinces, 3 European Countries and 3 Australian States. ADV NGA
US: 866-OLDCASTLE (653-2278)
www.obe.com

TRANSLUCENT

McGrory Glass Inc.
1400 Grandview Ave.
Paulsboro, NJ 08066
Phone: 800/220-3749
Fax: 856/579-3233
E-mail: sales@mcgrory.com
www.mcgrory.com

VARIABLE WIRED



Glassopolis
We Put Glass Contractors First
Fast Quotes. Fast Delivery
US: 800/262-9600
Fax: 800/872-9601
E-mail: sales@glassopolis.com
www.glassopolis.com

RAY BAR

RAY-BAR USA NGA
Fastest Fire Glass and IGU's Available
US: 800/444-9729
Fax: 800/333-9729
E-mail: sales@raybar.com
www.FireProofGlass.com

WIRED



GGI NGA ADV
101 Venture Way
Secaucus, NJ 07094
US: 800/431-2042
Phone: 201/553-1850
Fax: 201/553-1851
E-mail: sales@generalglass.com
www.generalglass.com

X-RAY SHIELDING

Amerope Enterprises Inc. NGA
150 Commerce Rd.
Boynton Beach, FL 33426
US: 800/327-3320
Phone: 561/737-7370
Fax: 561/737-3721
E-mail: claire@amerope.com
www.amerope.com



Glassopolis
We Put Glass Contractors First
Fast Quotes. Fast Delivery
US: 800/262-9600
Fax: 800/872-9601
E-mail: sales@glassopolis.com
www.glassopolis.com



McGRORYGLASS

McGrory Glass Inc.
1400 Grandview Ave.
Paulsboro, NJ 08066
Phone: 800/220-3749
Fax: 856/579-3233
E-mail: sales@mcgrory.com
www.mcgrory.com

RAY BAR

RAY-BAR USA NGA
Fastest X-Ray Glass and IGU's Available
US: 800/444-XRAY
Fax: 800/333-XRAY
E-mail: sales@raybar.com
www.raybar.com



Technical Glass Products NGA
8107 Bracken Place SE
Snoqualmie, WA 98065
Phone: 800/426-0279
Fax: 425/396-8300
E-mail: sales@fireglass.com
www.fireglass.com

BATH ENCLOSURES & RELATED ITEMS

GENERAL



American Insulated Glass ADV
7 Regional Fabrication Locations in the US
US: 866/519-1565
Phone: 404/361-9154
E-mail: sales@aiglass.com
www.aiglass.com



C.R. Laurence Co. Inc. ADV NGA
2503 E. Vernon Ave.
Los Angeles, CA 90058
US: 800/421-6144
E-mail: crl@crlaurence.com
www.crlaurence.com



Frameless Hardware Company NGA ADV
4361 Firestone Blvd.
South Gate, CA 90280
US: 888/295-4531
Phone: 323/968-2031
Fax: 323/336-8307
E-mail: info@fhc-usa.com
www.fhc-usa.com



Glassfab Tempering Services ADV
1448 Mariani Ct.
Tracy, CA 95304
US: 800/490-3860
Phone: 209/229-1060
Fax: 209/229-1061
E-mail: info@glassfabusa.com
www.glassfabusa.com

ENCLOSURES: CURVED



Precision Glass Bending Corp. ADV NGA
P.O. Box 1970
3811 Hwy. 10 West
Greenwood, AR 72936-1970
US: 800/543-8796
Phone: 479/996-8065
Fax: 800/543-8798
E-mail: sales@e-bentglass.com
www.e-bentglass.com
(See our ad on page 81)

ENCLOSURES: CUSTOM



GGI NGA ADV
101 Venture Way
Secaucus, NJ 07094
US: 800/431-2042
Phone: 201/553-1850
Fax: 201/553-1851
E-mail: sales@generalglass.com
www.generalglass.com

**ENCLOSURES:
FRAMELESS**



Frameless Hardware Company **NGA
ADV**
4361 Firestone Blvd.
South Gate, CA 90280
US: 888/295-4531
Phone: 323/968-2031
Fax: 323/336-8307
E-mail: info@fhc-usa.com
www.fhc-usa.com

**ENCLOSURES:
GLASS STALLS**



Oldcastle BuildingEnvelope®
More Than 85 Manufacturing and
Distribution Locations in 25 US
States, 4 Canadian Provinces, 3
European Countries and 3
Australian States. **ADV
NGA**
US: 866-OLDCASTLE
(653-2278)
www.obc.com

HARDWARE



Benowitz International Glass
Products, LLC **ADV
NGA**
"The Pinnacle of Innovation"
Phone: 702/885-4772
E-mail: sales@
benowitzinternationalglass.com
www.benowitzinternationalglass.com



C.R. Laurence Co. Inc. **ADV
NGA**
2503 E. Vernon Ave.
Los Angeles, CA 90058
US: 800/421-6144
E-mail: crl@claurence.com
www.claurence.com

Frameless Hardware Company **NGA
ADV**
4361 Firestone Blvd.
South Gate, CA 90280
US: 888/295-4531
Phone: 323/968-2031
Fax: 323/336-8307
E-mail: info@fhc-usa.com
www.fhc-usa.com



IGT Glass Hardware
5260 NW 167th St.
Miami Gardens, FL 33014
US: 877/545-7079
E-mail: sales@igt-glasshardware.com
www.glasshardware.com

Oldcastle BuildingEnvelope®
More Than 85 Manufacturing and
Distribution Locations in 25 US
States, 4 Canadian Provinces, 3
European Countries and 3
Australian States. **ADV
NGA**
US: 866-OLDCASTLE
(653-2278)
www.obc.com

Rockwell Security Inc.
15083 Wicks Blvd.
San Leandro, CA 94577
Phone: 510/270-5633
Fax: 309/276-2680
E-mail:
info@rockwellsecurityinc.com
www.rockwellsecurityinc.com
(See our ad on page 80)

SHOWER DOORS



Benowitz International Glass
Products, LLC **ADV
NGA**
"The Pinnacle of Innovation"
Phone: 702/885-4772
E-mail: sales@
benowitzinternationalglass.com
www.benowitzinternationalglass.com



C.R. Laurence Co. Inc. **ADV
NGA**
2503 E. Vernon Ave.
Los Angeles, CA 90058
US: 800/421-6144
E-mail: crl@claurence.com
www.claurence.com



Frameless Hardware Company **NGA
ADV**
4361 Firestone Blvd.
South Gate, CA 90280
US: 888/295-4531
Phone: 323/968-2031
Fax: 323/336-8307
E-mail: info@fhc-usa.com
www.fhc-usa.com

Oldcastle BuildingEnvelope®
More Than 85 Manufacturing and
Distribution Locations in 25 US
States, 4 Canadian Provinces, 3
European Countries and 3
Australian States. **ADV
NGA**
US: 866-OLDCASTLE
(653-2278)
www.obc.com

BENT GLASS

GENERAL

Curved Glass Creations
4100 Powerline Rd., Ste. T-2
Pompano Beach, FL 33073
US: 888/288-9129
Phone: 954/917-0039
Fax: 954/917-0040
E-mail:
info@curvedglasscreations.com
www.curvedglasscreations.com
(See our ad on this page)



Precision Glass Bending Corp. **ADV
NGA**
P.O. Box 1970
3811 Hwy. 10 West
Greenwood, AR 72936-1970
US: 800/543-8796
Phone: 479/996-8065
Fax: 800/543-8798
E-mail: sales@e-bentglass.com
www.e-bentglass.com
(See our ad on this page)



Standard Bent Glass **ADV
NGA**
P.O. Box 65
East Butler, PA 16029
Phone: 724/287-3747
www.standardbent.com

BENT/CURVED GLASS



Precision Glass Bending Corp. **ADV
NGA**
P.O. Box 1970
3811 Hwy. 10 West
Greenwood, AR 72936-1970
US: 800/543-8796
Phone: 479/996-8065
Fax: 800/543-8798
E-mail: sales@e-bentglass.com
www.e-bentglass.com
(See our ad on this page)

DECORATIVE



Standard Bent Glass **ADV
NGA**
P.O. Box 65
East Butler, PA 16029
Phone: 724/287-3747
www.standardbent.com

INSULATING



Precision Glass Bending Corp. **ADV
NGA**
P.O. Box 1970
3811 Hwy. 10 West
Greenwood, AR 72936-1970
US: 800/543-8796
Phone: 479/996-8065
Fax: 800/543-8798
E-mail: sales@e-bentglass.com
www.e-bentglass.com
(See our ad on this page)



Standard Bent Glass **ADV
NGA**
P.O. Box 65
East Butler, PA 16029
Phone: 724/287-3747
www.standardbent.com

LAMINATED



Precision Glass Bending Corp. **ADV
NGA**
P.O. Box 1970
3811 Hwy. 10 West
Greenwood, AR 72936-1970
US: 800/543-8796
Phone: 479/996-8065
Fax: 800/543-8798
E-mail: sales@e-bentglass.com
www.e-bentglass.com
(See our ad on this page)



Standard Bent Glass **ADV
NGA**
P.O. Box 65
East Butler, PA 16029
Phone: 724/287-3747
www.standardbent.com

SAFETY



Precision Glass Bending Corp. **ADV
NGA**
P.O. Box 1970
3811 Hwy. 10 West
Greenwood, AR 72936-1970
US: 800/543-8796
Phone: 479/996-8065
Fax: 800/543-8798
E-mail: sales@e-bentglass.com
www.e-bentglass.com
(See our ad on this page)

SPANDREL



Precision Glass Bending Corp. **ADV
NGA**
P.O. Box 1970
3811 Hwy. 10 West
Greenwood, AR 72936-1970
US: 800/543-8796
Phone: 479/996-8065
Fax: 800/543-8798
E-mail: sales@e-bentglass.com
www.e-bentglass.com
(See our ad on this page)

TEMPERED



Precision Glass Bending Corp. **ADV
NGA**
P.O. Box 1970
3811 Hwy. 10 West
Greenwood, AR 72936-1970
US: 800/543-8796
Phone: 479/996-8065
Fax: 800/543-8798
E-mail: sales@e-bentglass.com
www.e-bentglass.com
(See our ad on this page)

TEMPERED/LAMINATED



Standard Bent Glass **ADV
NGA**
P.O. Box 65
East Butler, PA 16029
Phone: 724/287-3747
www.standardbent.com

TEMPERED/LAMINATED



Precision Glass Bending Corp. **ADV
NGA**
P.O. Box 1970
3811 Hwy. 10 West
Greenwood, AR 72936-1970
US: 800/543-8796
Phone: 479/996-8065
Fax: 800/543-8798
E-mail: sales@e-bentglass.com
www.e-bentglass.com
(See our ad on this page)



Standard Bent Glass **ADV
NGA**
P.O. Box 65
East Butler, PA 16029
Phone: 724/287-3747
www.standardbent.com

The World Leader
in Custom Fabricated

**BENT
GLASS**

- SAFETY TEMPERED • INSULATED
- ANNEALED • SAFETY LAMINATED
- HEAT-STRENGTHENED

Radius or Irregular Bends
Sizes up to 96" x 130"
1/8" to 3/4" Thickness

Architectural, Interior,
Solar & Transport



Clear, Tinted, Low-E,
Reflective, Acid-Etch,
Low-Iron or Specialty

Polished Edges, Holes,
Notches, and Cutouts



Precision Glass Bending

(800) 543-8796 • FAX (800) 543-8798
www.e-bentglass.com
Guardian SunGuard Select™ Fabricator

**COMPUTER
SOFTWARE**

ACCOUNTING

Mainstreet Computers Inc. **ADV**
330 Charles St.
Belleville, MI 48111
US: 800/698-6246
Phone: 734/699-0025
Fax: 734/697-8228
E-mail:
sales@mainstreetcomp.com
www.mainstreetcomp.com

**CURVED GLASS
CREATIONS**

Quality Service Since 1946

SPECIALIZING IN:

- LAMINATED SAFETY GLASS
 - HEAT STRENGTHENED
 - INSULATED UNITS
 - ANNEALED
 - EXPEDITED LEAD TIMES
- FROM STOCK CURIO CABINET GLASS TO
SPIRAL STAIRCASE GLASS
WE DO IT ALL
- www.CurvedGlassCreations.com
Toll Free (888) 288-9129
Fax (954) 917-0040

Suppliers Guide

MarketPro
Point of Sale Solutions

THE FUTURE IS HERE!

DOORS | WINDOWS | GLASS

Run your entire company with just one POS Software!

- 📱 As user-friendly as your smartphone
- ⚙️ Increase efficiency
- 💰 Convert more sales
- 📊 System generated consistent pricing
- 👥 Get your team on the same page
- 📅 Integrated CRM
- 📅 Scheduling and dispatching
- 💳 Credit card processing
- 📍 Monitor your company from anywhere 24/7
- 📄 E sign contracts with product images
- 📄 Automated commission statements
- 📈 Grow your company fast!
- 📅 Project management
- 📍 Run multiple locations
- 🚀 Skyrocket your profits

Ray Bansal
408 210 4780
ray@marketpropos.com
www.marketpropos.com

BUSINESS

Mainstreet Computers Inc. ADV
330 Charles St.
Belleville, MI 48111
US: 800/698-6246
Phone: 734/699-0025
Fax: 734/697-8228
E-mail:
sales@mainstreetcomp.com
www.mainstreetcomp.com

GDS ESTIMATING

Fenestration software
made simple

EASILY CREATE

- Drawings
- Reports
- Quotes
- Cut Sheets

FREE TRIAL

858.538.4375
gdsestimating.com/try

CALL CENTERS

Mainstreet Computers Inc. ADV
330 Charles St.
Belleville, MI 48111
US: 800/698-6246
Phone: 734/699-0025
Fax: 734/697-8228
E-mail:
sales@mainstreetcomp.com
www.mainstreetcomp.com

ESTIMATING

GDS Storefront Estimating NGA
2033 San Elijo Ave. #221
Cardiff by the Sea, CA 92007
Phone: 858/538-4375
Fax: 858/538-4376
E-mail: sales@gdsestimating.com
www.gdsestimating.com
(See our ad on this page)

INVENTORY

Mainstreet Computers Inc. ADV
330 Charles St.
Belleville, MI 48111
US: 800/698-6246
Phone: 734/699-0025
Fax: 734/697-8228
E-mail:
sales@mainstreetcomp.com
www.mainstreetcomp.com

INVOICING

Mainstreet Computers Inc. ADV
330 Charles St.
Belleville, MI 48111
US: 800/698-6246
Phone: 734/699-0025
Fax: 734/697-8228
E-mail:
sales@mainstreetcomp.com
www.mainstreetcomp.com

MEASURE SHEET

Mainstreet Computers Inc. ADV
330 Charles St.
Belleville, MI 48111
US: 800/698-6246
Phone: 734/699-0025
Fax: 734/697-8228
E-mail:
sales@mainstreetcomp.com
www.mainstreetcomp.com

MOBILE TECH APP

Mainstreet Computers Inc. ADV
330 Charles St.
Belleville, MI 48111
US: 800/698-6246
Phone: 734/699-0025
Fax: 734/697-8228
E-mail:
sales@mainstreetcomp.com
www.mainstreetcomp.com

PAYMENT PROCESSING

Mainstreet Computers Inc. ADV
330 Charles St.
Belleville, MI 48111
US: 800/698-6246
Phone: 734/699-0025
Fax: 734/697-8228
E-mail:
sales@mainstreetcomp.com
www.mainstreetcomp.com

POINT OF SALE

Mainstreet Computers Inc. ADV
330 Charles St.
Belleville, MI 48111
US: 800/698-6246
Phone: 734/699-0025
Fax: 734/697-8228
E-mail:
sales@mainstreetcomp.com
www.mainstreetcomp.com

MarketPro Point of Sale Solutions
2372 Morse Ave., Ste. 674
Irvine, CA 92614
US: 888/616-3706
E-mail: support@marketpropos.com
www.marketpropos.com
(See our ad on this page)

PRICING

Mainstreet Computers Inc. ADV
330 Charles St.
Belleville, MI 48111
US: 800/698-6246
Phone: 734/699-0025
Fax: 734/697-8228
E-mail:
sales@mainstreetcomp.com
www.mainstreetcomp.com

SCHEDULING

Mainstreet Computers Inc. ADV
330 Charles St.
Belleville, MI 48111
US: 800/698-6246
Phone: 734/699-0025
Fax: 734/697-8228
E-mail:
sales@mainstreetcomp.com
www.mainstreetcomp.com

DECORATIVE GLASS

GENERAL



American Insulated Glass ADV
7 Regional Fabrication
Locations in the US
US: 866/519-1565
Phone: 404/361-9154
E-mail: sales@aiglass.com
Web: www.aiglass.com



McGRORY GLASS

McGrory Glass Inc.
1400 Grandview Ave.
Paulsboro, NJ 08066
Phone: 800/220-3749
Fax: 856/579-3233
E-mail: sales@mcgrory.com
www.mcgrory.com



Oldcastle BuildingEnvelope®
More Than 85 Manufacturing and
Distribution Locations in 25 US
States, 4 Canadian Provinces, 3
European Countries and 3
Australian States. **ADV NGA**
US: 866-OLDCASTLE
(653-2278)
www.obe.com



Standard Bent Glass ADV
P.O. Box 65
East Butler, PA 16029
Phone: 724/287-3747
www.standardbent.com

ACID ETCHED



GGI NGA ADV
101 Venture Way
Secaucus, NJ 07094
US: 800/431-2042
Phone: 201/553-1850
Fax: 201/553-1851
E-mail: sales@generalglass.com
www.generalglass.com

McGrory Glass Inc.
1400 Grandview Ave.
Paulsboro, NJ 08066
Phone: 800/220-3749
Fax: 856/579-3233
E-mail: sales@mcgrory.com
www.mcgrory.com

BACKLIT MIRRORS



Benowitz International Glass Products, LLC ADV
"The Pinnacle of Innovation"
Phone: 702/885-4772
E-mail: sales@benowitzinternationalglass.com
www.benowitzinternationalglass.com

CERAMIC FRIT: COLORED



Glassfab Tempering Services ADV
1448 Mariani Ct.
Tracy, CA 95304
US: 800/490-3860
Phone: 209/229-1060
Fax: 209/229-1061
E-mail: info@GlassfabUSA.com
www.GlassfabUSA.com

Oldcastle BuildingEnvelope®
More Than 85 Manufacturing and
Distribution Locations in 25 US
States, 4 Canadian Provinces, 3
European Countries and 3
Australian States. **ADV NGA**
US: 866-OLDCASTLE
(653-2278)
www.obe.com

CERAMIC FRIT: PATTERNED

Oldcastle BuildingEnvelope®
More Than 85 Manufacturing and
Distribution Locations in 25 US
States, 4 Canadian Provinces, 3
European Countries and 3
Australian States. **ADV NGA**
US: 866-OLDCASTLE
(653-2278)
www.obe.com

COLOR COATED



GGI NGA ADV
101 Venture Way
Secaucus, NJ 07094
US: 800/431-2042
Phone: 201/553-1850
Fax: 201/553-1851
E-mail: sales@generalglass.com
www.generalglass.com

McGrory Glass Inc.
1400 Grandview Ave.
Paulsboro, NJ 08066
Phone: 800/220-3749
Fax: 856/579-3233
E-mail: sales@mcgrory.com
www.mcgrory.com

DECORATIVE INTERLAYERS



Interlayer Solutions Inc.
6440 Boul. Henri Bourassa E.
Montreal, QC H1G 5W9 Canada
US: 855/873-1404
Phone: 514/326-4003
Fax: 514/326-9982
E-mail:
info@interlayersolutions.com
www.interlayersolutions.com

McGrory Glass Inc.
1400 Grandview Ave.
Paulsboro, NJ 08066
Phone: 800/220-3749
Fax: 856/579-3233
E-mail: sales@mcgrory.com
www.mcgrory.com



Standard Bent Glass ADV
P.O. Box 65
East Butler, PA 16029
Phone: 724/287-3747
www.standardbent.com

DICHROIC

McGrory Glass Inc.
1400 Grandview Ave.
Paulsboro, NJ 08066
Phone: 800/220-3749
Fax: 856/579-3233
E-mail: sales@mcgrory.com
www.mcgrory.com

DIGITAL DIRECT PRINTING



Glassfab Tempering Services ADV
1448 Mariani Ct.
Tracy, CA 95304
US: 800/490-3860
Phone: 209/229-1060
Fax: 209/229-1061
E-mail: info@GlassfabUSA.com
www.GlassfabUSA.com



GGI
101 Venture Way
Secaucus, NJ 07094
US: 800/431-2042
Phone: 201/553-1850
Fax: 201/553-1851
E-mail: sales@generalglass.com
www.generalglass.com



Oldcastle BuildingEnvelope®
More Than 85 Manufacturing and
Distribution Locations in 25 US
States, 4 Canadian Provinces, 3
European Countries and 3
Australian States. **ADV**
US: 866-OLDCASTLE **NGA**
(653-2278)
www.obe.com



Standard Bent Glass
P.O. Box 65
East Butler, PA 16029
Phone: 724/287-3747
www.standardbent.com

LAMINATED

McGrory Glass Inc.
1400 Grandview Ave.
Paulsboro, NJ 08066
Phone: 800/220-3749
Fax: 856/579-3233
E-mail: sales@mcgrory.com
www.mcgrory.com



Standard Bent Glass
P.O. Box 65
East Butler, PA 16029
Phone: 724/287-3747
www.standardbent.com

PAINTED

McGrory Glass Inc.
1400 Grandview Ave.
Paulsboro, NJ 08066
Phone: 800/220-3749
Fax: 856/579-3233
E-mail: sales@mcgrory.com
www.mcgrory.com

SAFETY

McGrory Glass Inc.
1400 Grandview Ave.
Paulsboro, NJ 08066
Phone: 800/220-3749
Fax: 856/579-3233
E-mail: sales@mcgrory.com
www.mcgrory.com

TEXTURED

McGrory Glass Inc.
1400 Grandview Ave.
Paulsboro, NJ 08066
Phone: 800/220-3749
Fax: 856/579-3233
E-mail: sales@mcgrory.com
www.mcgrory.com

DOOR HARDWARE & RELATED PRODUCTS

GENERAL

JLM Wholesale Inc. **NGA**
3095 Mullins Ct.
Oxford, MI 48371
US: 800/522-2940
Phone: 248/628-6440
Fax: 800/782-1160
E-mail: sales@jlmwholesale.com
www.jlmwholesale.com

Strybuc Industries **NGA**
2006 Elmwood Ave.
Building 102-C
Sharon Hill, PA 19079-0767
US (PA): 800/352-0800
US (FL): 800/780-5051
Fax: 610/534-3202
E-mail: cservice@strybuc.com
www.strybuc.com

ACCESS CONTROL

Frameless Hardware Company **NGA**
4361 Firestone Blvd. **ADV**
South Gate, CA 90280
US: 888/295-4531
Phone: 323/968-2031
Fax: 323/336-8307
E-mail: info@fhc-usa.com
www.fhc-usa.com

JLM Wholesale Inc. **ADV**
3095 Mullins Ct. **NGA**
Oxford, MI 48371
US: 800/522-2940
Phone: 248/628-6440
Fax: 800/782-1160
E-mail: sales@jlmwholesale.com
www.jlmwholesale.com

BUMPERS

JLM Wholesale Inc. **ADV**
3095 Mullins Ct. **NGA**
Oxford, MI 48371
US: 800/522-2940
Phone: 248/628-6440
Fax: 800/782-1160
E-mail: sales@jlmwholesale.com
www.jlmwholesale.com

CLOSING DEVICES

C.R. Laurence Co. Inc. **ADV**
2503 E. Vernon Ave. **NGA**
Los Angeles, CA 90058
US: 800/421-6144
E-mail: crl@crlaurence.com
www.crlaurence.com

JLM Wholesale Inc. **ADV**
3095 Mullins Ct. **NGA**
Oxford, MI 48371
US: 800/522-2940
Phone: 248/628-6440
Fax: 800/782-1160
E-mail: sales@jlmwholesale.com
www.jlmwholesale.com



Kenwa Trading
380 N. Broadway, Ste. 302
Jericho, NY 11050
Phone: 516/933-6016
Fax: 516/933-6018
E-mail: ktcc@kenwa.net
www.kenwa-america.com

DEADBOLTS

JLM Wholesale Inc. **ADV**
3095 Mullins Ct. **NGA**
Oxford, MI 48371
US: 800/522-2940
Phone: 248/628-6440
Fax: 800/782-1160
E-mail: sales@jlmwholesale.com
www.jlmwholesale.com

HANDLES

C.R. Laurence Co. Inc. **ADV**
2503 E. Vernon Ave. **NGA**
Los Angeles, CA 90058
US: 800/421-6144
E-mail: crl@crlaurence.com
www.crlaurence.com



Kenwa Trading
380 N. Broadway, Ste. 302
Jericho, NY 11050
Phone: 516/933-6016
Fax: 516/933-6018
E-mail: ktcc@kenwa.net
www.kenwa-america.com

HINGES

JLM Wholesale Inc. **ADV**
3095 Mullins Ct. **NGA**
Oxford, MI 48371
US: 800/522-2940
Phone: 248/628-6440
Fax: 800/782-1160
E-mail: sales@jlmwholesale.com
www.jlmwholesale.com

KICK PLATES

JLM Wholesale Inc. **ADV**
3095 Mullins Ct. **NGA**
Oxford, MI 48371
US: 800/522-2940
Phone: 248/628-6440
Fax: 800/782-1160
E-mail: sales@jlmwholesale.com
www.jlmwholesale.com

LATCHES

JLM Wholesale Inc. **ADV**
3095 Mullins Ct. **NGA**
Oxford, MI 48371
US: 800/522-2940
Phone: 248/628-6440
Fax: 800/782-1160
E-mail: sales@jlmwholesale.com
www.jlmwholesale.com

LOCKS

JLM Wholesale Inc. **ADV**
3095 Mullins Ct. **NGA**
Oxford, MI 48371
US: 800/522-2940
Phone: 248/628-6440
Fax: 800/782-1160
E-mail: sales@jlmwholesale.com
www.jlmwholesale.com

OPENING DEVICES

JLM Wholesale Inc. **ADV**
3095 Mullins Ct. **NGA**
Oxford, MI 48371
US: 800/522-2940
Phone: 248/628-6440
Fax: 800/782-1160
E-mail: sales@jlmwholesale.com
www.jlmwholesale.com

PANIC DEVICES



C.R. Laurence Co. Inc. **ADV**
2503 E. Vernon Ave. **NGA**
Los Angeles, CA 90058
US: 800/421-6144
E-mail: crl@crlaurence.com
www.crlaurence.com



Frameless Hardware Company **NGA**
4361 Firestone Blvd. **ADV**
South Gate, CA 90280
US: 888/295-4531
Phone: 323/968-2031
Fax: 323/336-8307
E-mail: info@fhc-usa.com
www.fhc-usa.com

JLM Wholesale Inc. **ADV**
3095 Mullins Ct. **NGA**
Oxford, MI 48371
US: 800/522-2940
Phone: 248/628-6440
Fax: 800/782-1160
E-mail: sales@jlmwholesale.com
www.jlmwholesale.com

PIVOTS

JLM Wholesale Inc. **ADV**
3095 Mullins Ct. **NGA**
Oxford, MI 48371
US: 800/522-2940
Phone: 248/628-6440
Fax: 800/782-1160
E-mail: sales@jlmwholesale.com
www.jlmwholesale.com

PUSH/PULL

JLM Wholesale Inc. **ADV**
3095 Mullins Ct. **NGA**
Oxford, MI 48371
US: 800/522-2940
Phone: 248/628-6440
Fax: 800/782-1160
E-mail: sales@jlmwholesale.com
www.jlmwholesale.com

RAILS



Frameless Hardware Company **NGA**
4361 Firestone Blvd. **ADV**
South Gate, CA 90280
US: 888/295-4531
Phone: 323/968-2031
Fax: 323/336-8307
E-mail: info@fhc-usa.com
www.fhc-usa.com

SLIDING GLASS DOOR

C.R. Laurence Co. Inc. **ADV**
2503 E. Vernon Ave. **NGA**
Los Angeles, CA 90058
US: 800/421-6144
E-mail: crl@crlaurence.com
www.crlaurence.com



Oldcastle BuildingEnvelope®
More Than 85 Manufacturing and
Distribution Locations in 25 US
States, 4 Canadian Provinces, 3
European Countries and 3 **ADV**
Australian States. **NGA**
US: 866-OLDCASTLE
(653-2278)
www.obe.com

STOPS & HOLDERS

JLM Wholesale Inc. **ADV**
3095 Mullins Ct. **NGA**
Oxford, MI 48371
US: 800/522-2940
Phone: 248/628-6440
Fax: 800/782-1160
E-mail: sales@jlmwholesale.com
www.jlmwholesale.com

SWEEPS

JLM Wholesale Inc. **ADV**
3095 Mullins Ct. **NGA**
Oxford, MI 48371
US: 800/522-2940
Phone: 248/628-6440
Fax: 800/782-1160
E-mail: sales@jlmwholesale.com
www.jlmwholesale.com

VISION PANEL FRAMES



Glassopolis
We Put Glass Contractors First
Fast Quotes, Fast Delivery
Phone: 800/262-9600
Fax: 800/872-9601
E-mail: sales@glassopolis.com
www.glassopolis.com



RAY-BAR USA **NGA**
Fastest Fire Glass and
IGU's Available
Phone: 800/444-9729
Fax: 800/333-9729
E-mail: sales@raybar.com
www.FireProofGlass.com

DOORS & RELATED PRODUCTS

GENERAL



GGI **NGA**
101 Venture Way **ADV**
Secaucus, NJ 07094
US: 800/431-2042
Phone: 201/553-1850
Fax: 201/553-1851
E-mail: sales@generalglass.com
www.generalglass.com

Come To The Source!

For Doors
 Also available:
 • Stock Lengths
 • Custom Windows
 • Custom Entrances

REBCO
 INCORPORATED
 TEL: (973) 684-0200 • FAX: (973) 684-0118
 (800) 777-0787 • www.REBCOinc.com
 1171-1225 Madison Ave., Paterson, NJ 07650-2248

GLASSFAB
 TEMPERING SERVICES, INC.

Glassfab Tempering Services **ADV**
 1448 Mariani Ct.
 Tracy, CA 95304
 US: 800/490-3860
 Phone: 209/229-1060
 Fax: 209/229-1061
 E-mail: info@GlassfabUSA.com
 www.GlassfabUSA.com

McGrory Glass Inc.
 1400 Grandview Ave.
 Paulsboro, NJ 08066
 Phone: 800/220-3749
 Fax: 856/579-3233
 E-mail: sales@mcgrory.com
 www.mcgrory.com

Oldcastle BuildingEnvelope
 A CRI COMPANY

Oldcastle BuildingEnvelope®
 More Than 85 Manufacturing and Distribution Locations in 25 US States, 4 Canadian Provinces, 3 European Countries and 3 Australian States. **ADV NGA**
 US: 866-OLDCASTLE (653-2278)
 www.obc.com

ALUMINUM

C.R. Laurence Co. Inc. **ADV NGA**
 2503 E. Vernon Ave.
 Los Angeles, CA 90058
 US: 800/421-6144
 E-mail: crl@claurence.com
 www.claurence.com

Oldcastle BuildingEnvelope®
 More Than 85 Manufacturing and Distribution Locations in 25 US States, 4 Canadian Provinces, 3 European Countries and 3 Australian States. **ADV NGA**
 US: 866-OLDCASTLE (653-2278)
 www.obc.com

BALCONIES: HIGH-RISE BUILDINGS

Oldcastle BuildingEnvelope®
 More Than 85 Manufacturing and Distribution Locations in 25 US States, 4 Canadian Provinces, 3 European Countries and 3 Australian States. **ADV NGA**
 US: 866-OLDCASTLE (653-2278)
 www.obc.com

BIFOLD

C.R. Laurence Co. Inc. **ADV NGA**
 2503 E. Vernon Ave.
 Los Angeles, CA 90058
 US: 800/421-6144
 E-mail: crl@claurence.com
 www.claurence.com

BLAST RESISTANT

RAY BAR

RAY-BAR USA **NGA**
 Security, Ballistic Glass and IGU's
 US: 800/444-9729
 Fax: 800/333-9729
 E-mail: sales@raybar.com
 www.raybar.com

Oldcastle BuildingEnvelope®
 More Than 85 Manufacturing and Distribution Locations in 25 US States, 4 Canadian Provinces, 3 European Countries and 3 Australian States. **ADV NGA**
 US: 866-OLDCASTLE (653-2278)
 www.obc.com

BULLET RESISTANT

McGrory Glass Inc.
 1400 Grandview Ave.
 Paulsboro, NJ 08066
 Phone: 800/220-3749
 Fax: 856/579-3233
 E-mail: sales@mcgrory.com
 www.mcgrory.com

RAY BAR

RAY-BAR USA **NGA**
 Security, Ballistic Glass and IGU's
 US: 800/444-9729
 Fax: 800/333-9729
 E-mail: sales@raybar.com
 www.raybar.com

ENTRANCE SYSTEMS: METAL

Oldcastle BuildingEnvelope®
 More Than 85 Manufacturing and Distribution Locations in 25 US States, 4 Canadian Provinces, 3 European Countries and 3 Australian States. **ADV NGA**
 US: 866-OLDCASTLE (653-2278)
 www.obc.com

FIRE-RATED

McGrory GLASS FIRE-RATED

McGrory Glass Inc.
 1400 Grandview Ave.
 Paulsboro, NJ 08066
 Phone: 800/220-3749
 Fax: 856/579-3233
 E-mail: sales@mcgrory.com
 www.mcgrory.com

GLASSOPOLIS

Glassopolis
 We Put Glass Contractors First
 Fast Quotes. Fast Delivery **ADV**
 Phone: 800/262-9600
 Fax: 800/872-9601
 E-mail: sales@glassopolis.com
 www.glassopolis.com

RAY BAR

RAY-BAR USA **NGA**
 Fastest Fire Glass and IGU's Available
 Phone: 800/444-9729
 Fax: 800/333-9729
 E-mail: sales@raybar.com
 www.FireProofGlass.com

SAFTIFIRST
 FIRE RATED GLAZING SOLUTIONS

SAFTI FIRST™ Fire Rated Glazing **ADV NGA**
 100 N. Hill Dr., Ste. 12
 Brisbane, CA 94005-1010
 US: 888/653-3333
 Phone: 415/824-4900
 Fax: 415/824-5900
 E-mail: info@safti.com
 www.safti.com

TGP FIRE RATED

Technical Glass Products **NGA**
 8107 Bracken Place SE
 Snoqualmie, WA 98065
 Phone: 800/426-0279
 Fax: 425/396-8300
 E-mail: sales@fireglass.com
 www.fireglass.com

Vetrotech Saint-Gobain Fire-Rated Glass and Framing **ADV NGA**
 2108 B St. NW, Ste. 110
 Auburn, WA 98001
 Phone: 888/803-9533
 E-mail: vetrotech.sales@saint-gobain.com
 www.vetrotechusa.com

GLASS

McGrory Glass Inc.
 1400 Grandview Ave.
 Paulsboro, NJ 08066
 Phone: 800/220-3749
 Fax: 856/579-3233
 E-mail: sales@mcgrory.com
 www.mcgrory.com

Oldcastle BuildingEnvelope®
 More Than 85 Manufacturing and Distribution Locations in 25 US States, 4 Canadian Provinces, 3 European Countries and 3 Australian States. **ADV NGA**
 US: 866-OLDCASTLE (653-2278)
 www.obc.com

INSULATING GLASS

Oldcastle BuildingEnvelope®
 More Than 85 Manufacturing and Distribution Locations in 25 US States, 4 Canadian Provinces, 3 European Countries and 3 Australian States. **ADV NGA**
 US: 866-OLDCASTLE (653-2278)
 www.obc.com

RAILINGS

BENOWITZ INTERNATIONAL Glass Products, LLC

Benowitz International Glass Products, LLC **ADV**
 "The Pinnacle of Innovation"
 Phone: 702/885-4772
 E-mail: sales@benowitzinternationalglass.com
 www.benowitzinternationalglass.com

CRL

C.R. Laurence Co. Inc. **ADV NGA**
 2503 E. Vernon Ave.
 Los Angeles, CA 90058
 US: 800/421-6144
 E-mail: crl@claurence.com
 www.claurence.com

IGT
 glasshardware.com

IGT Glass Hardware
 5260 NW 167th St.
 Miami Gardens, FL 33014
 US: 877/545-7079
 E-mail: sales@igt-glasshardware.com
 www.glasshardware.com

SAFETY GLASS

McGrory Glass Inc.
 1400 Grandview Ave.
 Paulsboro, NJ 08066
 Phone: 800/220-3749
 Fax: 856/579-3233
 E-mail: sales@mcgrory.com
 www.mcgrory.com

SECURITY

McGrory Glass Inc.
 1400 Grandview Ave.
 Paulsboro, NJ 08066
 Phone: 800/220-3749
 Fax: 856/579-3233
 E-mail: sales@mcgrory.com
 www.mcgrory.com

RAY BAR

RAY-BAR USA **NGA**
 Security, Ballistic Glass and IGU's
 US: 800/444-9729
 Fax: 800/333-9729
 E-mail: sales@raybar.com
 www.raybar.com

RIOT GLASS

Riot Glass LLC **ADV**
 17941 Brookshire Ln.
 Huntington Beach, CA 92647
 US: 800/580-2303
 Phone: 714/904-1030
 E-mail: brad@riotglass.com
 www.riotglass.com

TGP FIRE RATED

Technical Glass Products **NGA**
 8107 Bracken Place SE
 Snoqualmie, WA 98065
 Phone: 800/426-0279
 Fax: 425/396-8300
 E-mail: sales@fireglass.com
 www.fireglass.com

SECURITY GLAZING

Oldcastle BuildingEnvelope®
 More Than 85 Manufacturing and Distribution Locations in 25 US States, 4 Canadian Provinces, 3 European Countries and 3 Australian States. **ADV NGA**
 US: 866-OLDCASTLE (653-2278)
 www.obc.com

SIDELITES

McGrory Glass Inc.
 1400 Grandview Ave.
 Paulsboro, NJ 08066
 Phone: 800/220-3749
 Fax: 856/579-3233
 E-mail: sales@mcgrory.com
 www.mcgrory.com

SLIDING GLASS

C.R. Laurence Co. Inc. **ADV NGA**
 2503 E. Vernon Ave.
 Los Angeles, CA 90058
 US: 800/421-6144
 E-mail: crl@claurence.com
 www.claurence.com

STOREFRONTS & ENTRANCES

CRL

C.R. Laurence Co. Inc. **ADV NGA**
 2503 E. Vernon Ave.
 Los Angeles, CA 90058
 US: 800/421-6144
 E-mail: crl@claurence.com
 www.claurence.com

FHC

Frameless Hardware Company **NGA ADV**
 THE GLAZING SUPPLY COMPANY
 EXPERIENCE AND INNOVATION
 4361 Firestone Blvd.
 South Gate, CA 90280
 US: 888/295-4531
 Phone: 323/968-2031
 Fax: 323/336-8307
 E-mail: info@fhc-usa.com
 www.fhc-usa.com

McGrory Glass Inc.
1400 Grandview Ave.
Paulsboro, NJ 08066
Phone: 800/220-3749
Fax: 856/579-3233
E-mail: sales@mcgrory.com
www.mcgrory.com

REBCO Inc.
1171-1225 Madison Ave.
Paterson, NJ 07509-2248
US: 800/777-0787
Phone: 973/684-0200
Fax: 973/684-0118
E-mail: sales@REBCOinc.com
www.REBCOinc.com
(See our ad on page 84)

Oldcastle BuildingEnvelope®
More Than 85 Manufacturing and
Distribution Locations in 25 US
States, 4 Canadian Provinces, 3
European Countries and 3
Australian States. **ADV**
US: 866-OLDCASTLE **NGA**
(653-2278) 
www.obe.com

**Vetrotech Saint-Gobain Fire-
Rated Glass and Framing** **ADV**
2108 B St. NW, Ste. 110 **NGA**
Auburn, WA 98001 
Phone: 888/803-9533
E-mail:
vetrotech.sales@saint-gobain.com
www.vetrotechusa.com

**TEMPERED GLASS
DOORS**

Frameless Hardware Company **NGA**
4361 Firestone Blvd. **ADV**
South Gate, CA 90280
US: 888/295-4531
Phone: 323/968-2031
Fax: 323/336-8307
E-mail: info@fhc-usa.com
www.fhc-usa.com

McGrory Glass Inc.
1400 Grandview Ave.
Paulsboro, NJ 08066
Phone: 800/220-3749
Fax: 856/579-3233
E-mail: sales@mcgrory.com
www.mcgrory.com

Oldcastle BuildingEnvelope®
More Than 85 Manufacturing and
Distribution Locations in 25 US
States, 4 Canadian Provinces, 3
European Countries and 3
Australian States. **ADV**
US: 866-OLDCASTLE **NGA**
(653-2278) 
www.obe.com



SAFTI FIRST™ Fire Rated Glazing **ADV**
100 N. Hill Dr., Ste. 12 **NGA**
Brisbane, CA 94005-1010
US: 888/653-3333
Phone: 415/824-4900
Fax: 415/824-5900
E-mail: info@safti.com
www.safti.com

FILMS/COATINGS

ARCHITECTURAL

McGrory Glass Inc.
1400 Grandview Ave.
Paulsboro, NJ 08066
Phone: 800/220-3749
Fax: 856/579-3233
E-mail: sales@mcgrory.com
www.mcgrory.com

DECORATIVE



Interlayer Solutions Inc.
6440 Boul. Henri Bourassa E.
Montreal, QC H1G 5W9 Canada
US: 855/873-1404
Phone: 514/326-4003
Fax: 514/326-9982
E-mail:
info@interlayersolutions.com
www.interlayersolutions.com



McGRORY GLASS

McGrory Glass Inc.
1400 Grandview Ave.
Paulsboro, NJ 08066
Phone: 800/220-3749
Fax: 856/579-3233
E-mail: sales@mcgrory.com
www.mcgrory.com

**ELECTRICALLY
SWITCHABLE**

McGrory Glass Inc.

1400 Grandview Ave.
Paulsboro, NJ 08066
Phone: 800/220-3749
Fax: 856/579-3233
E-mail: sales@mcgrory.com
www.mcgrory.com

SAFETY & SECURITY



Interlayer Solutions Inc.
6440 Boul. Henri Bourassa E.
Montreal, QC H1G 5W9 Canada
US: 855/873-1404
Phone: 514/326-4003
Fax: 514/326-9982
E-mail:
info@interlayersolutions.com
www.interlayersolutions.com



Riot Glass LLC **ADV**
17941 Brookshire Ln.
Huntington Beach, CA 92647
US: 800/580-2303
Phone: 714/904-1030
E-mail: brad@riotglass.com
www.riotglass.com

**WATER RESISTANT
PROTECTIVE**



Interlayer Solutions Inc.
6440 Boul. Henri Bourassa E.
Montreal, QC H1G 5W9 Canada
US: 855/873-1404
Phone: 514/326-4003
Fax: 514/326-9982
E-mail:
info@interlayersolutions.com
www.interlayersolutions.com

**GLASS HANDLING,
PACKAGING & STORAGE**

CRANES



Microcranes, Inc.
10000 NE 7th Ave Ste 330-A
Vancouver, WA 98685
Phone: (360) 768-5104
Fax: (360) 326-7228
Email: info@microcranes.com
Website: www.smartrigranes.com

HANDLING EQUIPMENT



Ergo Robotic Solutions **ADV**
P.O. Box 503
Glens Falls, NY 12801
Phone: 518/796-2179
E-mail: j.nudi@ergorobotic.com
ErgoRobotic.com
(See our ad on this page)

**GLASS TOOLS
& SUPPLIES**

GENERAL



C.R. Laurence Co. Inc. **ADV**
2503 E. Vernon Ave. **NGA**
Los Angeles, CA 90058
US: 800/421-6144
E-mail: crl@crlaurence.com
www.crlaurence.com



Frameless Hardware Company **NGA**
4361 Firestone Blvd. **ADV**
South Gate, CA 90280
US: 888/295-4531
Phone: 323/968-2031
Fax: 323/336-8307
E-mail: info@fhc-usa.com
www.fhc-usa.com

BITS: DIAMOND

Glassline Corp.
28905 Glenwood Rd. 
P.O. Box 147
Perrysburg, OH 43552
Phone: 419/666-5942
Fax: 419/666-1549
E-mail: sales@glassline.com
www.glassline.com



IGP Tools **NGA**
1477 Connelly Springs Rd. 
Lenoir, NC 28645
US: 800/438-7542
Phone: 828/728-5338
Fax: 828/728-9613
E-mail: c.osborne@igptools.com
www.igptools.com

COOLANT



IGP Tools **NGA**
1477 Connelly Springs Rd. 
Lenoir, NC 28645
US: 800/438-7542
Phone: 828/728-5338
Fax: 828/728-9613
E-mail: c.osborne@igptools.com
www.igptools.com

**POLISHING
COMPOUNDS**



IGP Tools **NGA**
1477 Connelly Springs Rd. 
Lenoir, NC 28645
US: 800/438-7542
Phone: 828/728-5338
Fax: 828/728-9613
E-mail: c.osborne@igptools.com
www.igptools.com

TAPES



Interlayer Solutions Inc.
6440 Boul. Henri Bourassa E.
Montreal, QC H1G 5W9 Canada
US: 855/873-1404
Phone: 514/326-4003
Fax: 514/326-9982
E-mail:
info@interlayersolutions.com
www.interlayersolutions.com

WHEELS: DIAMOND

Glassline Corp.
28905 Glenwood Rd. 
P.O. Box 147
Perrysburg, OH 43552
Phone: 419/666-5942
Fax: 419/666-1549
E-mail: sales@glassline.com
www.glassline.com



IGP Tools **NGA**
1477 Connelly Springs Rd. 
Lenoir, NC 28645
US: 800/438-7542
Phone: 828/728-5338
Fax: 828/728-9613
E-mail: c.osborne@igptools.com
www.igptools.com

ERGO ROBOTIC SOLUTIONS

The GM 2000-26

Set
2000 lb.
glass **26'**
high, with
control &
precision.

34" wide
to fit
through
a 3' door!

518-796-2179
j.nudi@ergorobotic.com
ErgoRobotic.com



WHEELS: POLISHING



IGP Tools **NGA**
1477 Connelly Springs Rd. 
Lenoir, NC 28645
US: 800/438-7542
Phone: 828/728-5338
Fax: 828/728-9613
E-mail: c.osborne@igptools.com
www.igptools.com

**INSULATING GLASS
PRODUCTS, COMPONENTS
& EQUIPMENT**

GENERAL



American Insulated Glass **ADV**
American Insulated Glass
7 Regional Fabrication
Locations in the US 
US: 866/519-1565
Phone: 404/361-9154
E-mail: sales@aiglass.com
Web: www.aiglass.com

Suppliers Guide

**FABRICATING
EQUIPMENT SPECIALIST**

**MUNTIIN/SPACER RADIUS
FORMER**

**COMPUTERIZED/PNEUMATIC
NOTCHERS**

**SUNBURST LAYOUT TABLE
SYSTEM**

**SAWS-BLADES
MUNTIN/SPACER PUNCHES
FISHMOUTH EQUIPMENT**



EQUIPMENT & SUPPLY
734-459-5870 FAX 734-459-9837
WWW.MCKEEGANEQUIP.COM

Erdman Automation ADV
1603 S. 14th St.
Princeton, MN 55371
US: 866/376-6177
Phone: 763/389-9475
Fax: 763/389-9757
E-mail:
eac@erdmanautomation.com
www.erdmanautomation.com



Glassfab Tempering Services ADV
1448 Mariani Ct.
Tracy, CA 95304
US: 800/490-3860
Phone: 209/229-1060
Fax: 209/229-1061
E-mail: info@GlassfabUSA.com
www.GlassfabUSA.com

McKeegan Equipment & Supply ADV
8411 Ronda Dr.
Canton, MI 48187
Phone: 734/459-5870
Fax: 734/459-9837
E-mail:
sales@mckeeganequip.com
www.mckeeganequip.com
(See our ad on this page)



Oldcastle BuildingEnvelope® ADV NGA
More Than 85 Manufacturing and
Distribution Locations in 25 US
States, 4 Canadian Provinces, 3
European Countries and 3
Australian States.
US: 866-OLDCASTLE
(653-2278)
www.obe.com



Prelco Inc. ADV NGA
94 Cartier Blvd.
Riviere-du-Loup, GQ G5R 2M9
Canada
US: 800/463-1325
Phone: 418/862-2274
Fax: 418/862-8181
E-mail: sales@prelco.ca
www.prelco.ca

AIR SPACERS

Helima Helvetion International Inc
P.O. Box 1348
Duncan, SC 29334-1348
US: 800/346-6628
Phone: 864/439-6600
Fax: 864/439-6065
E-mail: tmccall@helimasc.com
www.helima.de

AIR SPACERS: WARM EDGE

Helima Helvetion International Inc
P.O. Box 1348
Duncan, SC 29334-1348
US: 800/346-6628
Phone: 864/439-6600
Fax: 864/439-6065
E-mail: tmccall@helimasc.com
www.helima.de

EQUIPMENT: OVENS

Casso-Solar Technologies ADV NGA
506 Airport Executive Park
Nanuet, NY 10954
Phone: 845/354-2010
Fax: 845/547-0328
E-mail:
sales@cassosolartechnologies.com
www.cassosolartechnologies.com

MUNTIN BARS

Helima Helvetion International Inc
P.O. Box 1348
Duncan, SC 29334-1348
US: 800/346-6628
Phone: 864/439-6600
Fax: 864/439-6065
E-mail: tmccall@helimasc.com
www.helima.de

UNITS: DOUBLE

Oldcastle BuildingEnvelope® ADV NGA
More Than 85 Manufacturing and
Distribution Locations in 25 US
States, 4 Canadian Provinces, 3
European Countries and 3
Australian States.
US: 866-OLDCASTLE
(653-2278)
www.obe.com

UNITS: TRIPLE

Oldcastle BuildingEnvelope® ADV NGA
More Than 85 Manufacturing and
Distribution Locations in 25 US
States, 4 Canadian Provinces, 3
European Countries and 3
Australian States.
US: 866-OLDCASTLE
(653-2278)
www.obe.com

INTERIOR OFFICE PARTITIONS

DEMOUNTABLE

C.R. Laurence Co. Inc. ADV NGA
2503 E. Vernon Ave.
Los Angeles, CA 90058
US: 800/421-6144
E-mail: crl@crlaurence.com
www.crlaurence.com

Oldcastle BuildingEnvelope®
More Than 85 Manufacturing and
Distribution Locations in 25 US
States, 4 Canadian Provinces, 3
European Countries and 3
Australian States.
US: 866-OLDCASTLE
(653-2278)
www.obe.com

FRAMELESS



Frameless Hardware Company ADV NGA
4361 Firestone Blvd.
South Gate, CA 90280
US: 888/295-4531
Phone: 323/968-2031
Fax: 323/336-8307
E-mail: info@fhc-usa.com
www.fhc-usa.com

LAMINATED GLASS & EQUIPMENT

GENERAL



American Insulated Glass ADV
7 Regional Fabrication
Locations in the US
US: 866/519-1565
Phone: 404/361-9154
E-mail: sales@aiglass.com
Web: www.aiglass.com

Amerope Enterprises Inc. NGA
150 Commerce Rd.
Boynton Beach, FL 33426
US: 800/327-3320
Phone: 561/737-7370
Fax: 561/737-3721
E-mail: claire@amerope.com
www.amerope.com



Casso-Solar Technologies ADV NGA
506 Airport Executive Park
Nanuet, NY 10954
Phone: 845/354-2010
Fax: 845/547-0328
E-mail:
sales@cassosolartechnologies.com
www.cassosolartechnologies.com



Glassfab Tempering Services ADV
1448 Mariani Ct.
Tracy, CA 95304
US: 800/490-3860
Phone: 209/229-1060
Fax: 209/229-1061
E-mail: info@GlassfabUSA.com
www.GlassfabUSA.com



Interlayer Solutions Inc.
6440 Boul. Henri Bourassa E.
Montreal, QC H1G 5W9 Canada
US: 855/873-1404
Phone: 514/326-4003
Fax: 514/326-9982
E-mail:
info@interlayersolutions.com
www.interlayersolutions.com

McGrory Glass Inc.
1400 Grandview Ave.
Paulsboro, NJ 08066
Phone: 800/220-3749
Fax: 856/579-3233
E-mail: sales@mcgrory.com
www.mcgrory.com



Oldcastle BuildingEnvelope® ADV NGA
More Than 85 Manufacturing and
Distribution Locations in 25 US
States, 4 Canadian Provinces, 3
European Countries and 3
Australian States.
US: 866-OLDCASTLE
(653-2278)
www.obe.com



Prelco Inc. ADV
94 Cartier Blvd.
Riviere-du-Loup, GQ G5R 2M9
Canada
US: 800/463-1325
Phone: 418/862-2274
Fax: 418/862-8181
E-mail: sales@prelco.ca
www.prelco.ca

EQUIPMENT: AUTOCLAVE



Casso-Solar Technologies ADV NGA
506 Airport Executive Park
Nanuet, NY 10954
Phone: 845/354-2010
Fax: 845/547-0328
E-mail:
sales@cassosolartechnologies.com
www.cassosolartechnologies.com

EQUIPMENT: AUTOMATED

Casso-Solar Technologies ADV NGA
506 Airport Executive Park
Nanuet, NY 10954
Phone: 845/354-2010
Fax: 845/547-0328
E-mail:
sales@cassosolartechnologies.com
www.cassosolartechnologies.com

EQUIPMENT: NON-AUTOCLAVE



Casso-Solar Technologies ADV NGA
506 Airport Executive Park
Nanuet, NY 10954
Phone: 845/354-2010
Fax: 845/547-0328
E-mail:
sales@cassosolartechnologies.com
www.cassosolartechnologies.com

EQUIPMENT: OVENS & PRESSES



Casso-Solar Technologies ADV NGA
506 Airport Executive Park
Nanuet, NY 10954
Phone: 845/354-2010
Fax: 845/547-0328
E-mail:
sales@cassosolartechnologies.com
www.cassosolartechnologies.com

EQUIPMENT: VACUUM SYSTEMS



Casso-Solar Technologies ADV NGA
506 Airport Executive Park
Nanuet, NY 10954
Phone: 845/354-2010
Fax: 845/547-0328
E-mail:
sales@cassosolartechnologies.com
www.cassosolartechnologies.com

GLASS CLAD POLYCARBONATE

Oldcastle BuildingEnvelope® ADV NGA
More Than 85 Manufacturing and
Distribution Locations in 25 US
States, 4 Canadian Provinces, 3
European Countries and 3
Australian States.
US: 866-OLDCASTLE
(653-2278)
www.obe.com



Riot Glass LLC ADV
17941 Brookshire Ln.
Huntington Beach, CA 92647
US: 800/580-2303
Phone: 714/904-1030
E-mail: brad@riotglass.com
www.riotglass.com

HURRICANE GLASS

SAFTI FIRST™ Fire Rated Glazing ADV NGA
100 N. Hill Dr., Ste. 12
Brisbane, CA 94005-1010
US: 888/653-3333
Phone: 415/824-4900
Fax: 415/824-5900
E-mail: info@safti.com
www.safti.com

Oldcastle BuildingEnvelope®

More Than 85 Manufacturing and Distribution Locations in 25 US States, 4 Canadian Provinces, 3 European Countries and 3 Australian States.
US: 866-OLDCASTLE (653-2278)
www.obc.com



INTERLAYER

INTERLAYER SOLUTIONS
EVALAYER
EVA films and more

Interlayer Solutions Inc.
6440 Boul. Henri Bourassa E.
Montreal, QC H1G 5W9 Canada
US: 855/873-1404
Phone: 514/326-4003
Fax: 514/326-9982
E-mail:
info@interlayersolutions.com
www.interlayersolutions.com

MIRRORS

Go to category **MIRRORS & RELATED PRODUCTS**

NON-REFLECTIVE: CLEAR

McGrory Glass Inc.
1400 Grandview Ave.
Paulsboro, NJ 08066
Phone: 800/220-3749
Fax: 856/579-3233
E-mail: sales@mcgrory.com
www.mcgrory.com

POLYCARBONATE LAMINATES

INTERLAYER SOLUTIONS
EVALAYER
EVA films and more

Interlayer Solutions Inc.
6440 Boul. Henri Bourassa E.
Montreal, QC H1G 5W9 Canada
US: 855/873-1404
Phone: 514/326-4003
Fax: 514/326-9982
E-mail:
info@interlayersolutions.com
www.interlayersolutions.com



RIOT GLASS



Riot Glass LLC
17941 Brookshire Ln.
Huntington Beach, CA 92647
US: 800/580-2303
Phone: 714/904-1030
E-mail: brad@riotglass.com
www.riotglass.com

SAFETY

INTERLAYER SOLUTIONS
EVALAYER
EVA films and more

Interlayer Solutions Inc.
6440 Boul. Henri Bourassa E.
Montreal, QC H1G 5W9 Canada
US: 855/873-1404
Phone: 514/326-4003
Fax: 514/326-9982
E-mail:
info@interlayersolutions.com
www.interlayersolutions.com

WIRED



Glassopolis

We Put Glass Contractors First
Fast Quotes, Fast Delivery
Phone: 800/262-9600
Fax: 800/872-9601
E-mail: sales@glassopolis.com
www.glassopolis.com

MACHINERY & EQUIPMENT

GENERAL



Casso-Solar Technologies

506 Airport Executive Park
Nanuet, NY 10954
Phone: 845/354-2010
Fax: 845/547-0328
E-mail:
sales@cassosolartechnologies.com
www.cassosolartechnologies.com



Erdman Automation

1603 S. 14th St.
Princeton, MN 55371
US: 866/376-6177
Phone: 763/389-9475
Fax: 763/389-9757
E-mail:
eac@erdmanautomation.com
www.erdmanautomation.com



ASSEMBLY

Mueller TB Technologies AG

Laubisruetistrasse 72
CH-8712 Staefa
Switzerland
Phone: 905/427-3400
Fax: +41-44-926-6774
E-mail: info@ejindustries.ca
www.mueller.ch
(See our ad on page 88)



BENDING



Casso-Solar Technologies

506 Airport Executive Park
Nanuet, NY 10954
Phone: 845/354-2010
Fax: 845/547-0328
E-mail:
sales@cassosolartechnologies.com
www.cassosolartechnologies.com



BEVELING



Lattuada North America Inc.
6967 Wales Rd., Ste. F
Northwood, OH 43619
Toll Free: 844/243-4486
Phone: 567/249-4486
E-mail: info@lattuada-na.com
www.lattuada-na.com



CENTRIFUGE

Glassline Corp.

28905 Glenwood Rd.
P.O. Box 147
Perrysburg, OH 43552
Phone: 419/666-5942
Fax: 419/666-1549
E-mail: sales@glassline.com
www.glassline.com



CNC CUTTING

Eastman®

Eastman Machine Company
779 Washington St.
Buffalo, NY 14203
US: 800/872-5571
Phone: 716/856-2200
Fax: 716/856-1140
E-mail: sales@eastmancuts.com
www.eastmancuts.com



COATING



Casso-Solar Technologies

506 Airport Executive Park
Nanuet, NY 10954
Phone: 845/354-2010
Fax: 845/547-0328
E-mail:
sales@cassosolartechnologies.com
www.cassosolartechnologies.com



CUTTING

Glassline Corp.

28905 Glenwood Rd.
P.O. Box 147
Perrysburg, OH 43552
Phone: 419/666-5942
Fax: 419/666-1549
E-mail: sales@glassline.com
www.glassline.com



DECORATING



Casso-Solar Technologies

506 Airport Executive Park
Nanuet, NY 10954
Phone: 845/354-2010
Fax: 845/547-0328
E-mail:
sales@cassosolartechnologies.com
www.cassosolartechnologies.com



DIGITAL TEMPLATES



Prodim USA

7454 Commercial Circle
Fort Pierce, FL 34951
888/229-3328
Phone: 772/465-4000
Fax: 772/465-8700
E-mail: info@prodimusa.com
www.prodim-systems.com

DRILLING



Lattuada North America Inc.
6967 Wales Rd., Ste. F
Northwood, OH 43619
Toll Free: 844/243-4486
Phone: 567/249-4486
E-mail: info@lattuada-na.com
www.lattuada-na.com



Glassline Corp.

28905 Glenwood Rd.
P.O. Box 147
Perrysburg, OH 43552
Phone: 419/666-5942
Fax: 419/666-1549
E-mail: sales@glassline.com
www.glassline.com



DRYING



Casso-Solar Technologies

506 Airport Executive Park
Nanuet, NY 10954
Phone: 845/354-2010
Fax: 845/547-0328
E-mail:
sales@cassosolartechnologies.com
www.cassosolartechnologies.com



Glassline Corp.

28905 Glenwood Rd.
P.O. Box 147
Perrysburg, OH 43552
Phone: 419/666-5942
Fax: 419/666-1549
E-mail: sales@glassline.com
www.glassline.com



EDGING



Lattuada North America Inc.
6967 Wales Rd., Ste. F
Northwood, OH 43619
Toll Free: 844/243-4486
Phone: 567/249-4486
E-mail: info@lattuada-na.com
www.lattuada-na.com



Glassline Corp.

28905 Glenwood Rd.
P.O. Box 147
Perrysburg, OH 43552
Phone: 419/666-5942
Fax: 419/666-1549
E-mail: sales@glassline.com
www.glassline.com



FURNACES

Casso-Solar Technologies

506 Airport Executive Park
Nanuet, NY 10954
Phone: 845/354-2010
Fax: 845/547-0328
E-mail:
sales@cassosolartechnologies.com
www.cassosolartechnologies.com



Jordan Glass Machinery

OUR TOP SELLER

D.J.M.G.L. - PUSHER W/ MITER

TOP MACHINERY OF 2022

- CNC CUTTING TABLES
- CHEMICAL TEMPERING OVEN
- TEMPERING FURNACE
- GLASS WRAPPING MACHINES
- WATER FILTRATING SYSTEMS

HUGE SELECTION OF MACHINES & TONS OF SPARE PARTS AVAILABLE

WWW.JORDONGLASS.COM
SALES@JORDONGLASS.COM
(305) 482-0116

GRINDING & POLISHING



Lattuada North America Inc.
6967 Wales Rd., Ste. F
Northwood, OH 43619
Toll Free: 844/243-4486
Phone: 567/249-4486
E-mail: info@lattuada-na.com
www.lattuada-na.com



HEATING ELEMENTS

Casso-Solar Technologies

506 Airport Executive Park
Nanuet, NY 10954
Phone: 845/354-2010
Fax: 845/547-0328
E-mail:
sales@cassosolartechnologies.com
www.cassosolartechnologies.com



INSPECTION SYSTEMS

Casso-Solar Technologies

506 Airport Executive Park
Nanuet, NY 10954
Phone: 845/354-2010
Fax: 845/547-0328
E-mail:
sales@cassosolartechnologies.com
www.cassosolartechnologies.com



INSULATING GLASS

Go to category **INSULATING GLASS PRODUCTS, COMPONENTS & EQUIPMENT**

LAMINATING

Go to category **LAMINATING GLASS & EQUIPMENT**

Suppliers Guide



MÜLLER TECHNOLOGIES

Are you going to start producing thermally insulated profiles or do you need to extend your current production drastically? As the leading manufacturer for Thermal Break Assembly Lines we can offer you fully automated lines as well as basic equipment to start your production.

We also manufacture other equipment for aluminum profiles, such as protection taping machines, gasket inserting devices, shear force testing units and other useful components.

Müller TB Technologies | +41 44 926 44 88
 sales@muller.ch | www.muller.ch

LASERS: MARKING

Casso-Solar Technologies **ADV NGA**
 506 Airport Executive Park
 Nanuet, NY 10954
 Phone: 845/354-2010
 Fax: 845/547-0328
 E-mail:
 sales@cassosolartechnologies.com
 www.cassosolartechnologies.com

LEHRs

Casso-Solar Technologies **ADV NGA**
 506 Airport Executive Park
 Nanuet, NY 10954
 Phone: 845/354-2010
 Fax: 845/547-0328
 E-mail:
 sales@cassosolartechnologies.com
 www.cassosolartechnologies.com

PAINTING

Casso-Solar Technologies **ADV NGA**
 506 Airport Executive Park
 Nanuet, NY 10954
 Phone: 845/354-2010
 Fax: 845/547-0328
 E-mail:
 sales@cassosolartechnologies.com
 www.cassosolartechnologies.com

PHOTOVOLTAIC PANEL EQUIPMENT MFG. SYSTEMS

Casso-Solar Technologies **ADV NGA**
 506 Airport Executive Park
 Nanuet, NY 10954
 Phone: 845/354-2010
 Fax: 845/547-0328
 E-mail:
 sales@cassosolartechnologies.com
 www.cassosolartechnologies.com

SCREEN PRINTING

AWT World Trade Inc.
 4321 N. Knox Ave.
 Chicago, IL 60641
 Phone: 773/777-7100
 Fax: 773/777-0909
 E-mail: sales@awt-gpi.com
 www.awt-gpi.com

Glassline Corp.
 28905 Glenwood Rd.
 P.O. Box 147
 Perrysburg, OH 43552
 Phone: 419/666-5942
 Fax: 419/666-1549
 E-mail: sales@glassline.com
 www.glassline.com

SEAMING

Glassline Corp.
 28905 Glenwood Rd.
 P.O. Box 147
 Perrysburg, OH 43552
 Phone: 419/666-5942
 Fax: 419/666-1549
 E-mail: sales@glassline.com
 www.glassline.com

SPRAYING

Casso-Solar Technologies **ADV NGA**
 506 Airport Executive Park
 Nanuet, NY 10954
 Phone: 845/354-2010
 Fax: 845/547-0328
 E-mail:
 sales@cassosolartechnologies.com
 www.cassosolartechnologies.com

TEMPERING



Xinglass
 Xinglass (Hangzhou Glass Technology Co., Ltd.)
 4445 Corporation Lane, Ste. 264
 Virginia Beach, VA 23462
 US: 800/868-0307
 Phone: 302/489-9583
 Fax: 302/231-2195
 E-mail:
 sales@xinglassamerica.com
 www.xinglass.com
 www.xinglassamerica.com

Jordon Glass Machinery **NGA**
 6320 NW 99th Ave.
 Doral, FL 33178
 US: 800/833-2159
 Phone: 305/482-0116
 Fax: 305/482-0119
 www.jordonglass.com
(See our ad on page 87)

WASHING

LATTUADA NORTH AMERICA **ADV NGA**
 LaLattuada North America Inc.
 6967 Wales Rd., Ste. F
 Northwood, OH 43619
 Toll Free: 844/243-4486
 Phone: 567/249-4486
 E-mail: info@lattuada-na.com
 www.lattuada-na.com

WATER JET CUTTING

Glassline Corp.
 28905 Glenwood Rd.
 P.O. Box 147
 Perrysburg, OH 43552
 Phone: 419/666-5942
 Fax: 419/666-1549
 E-mail: sales@glassline.com
 www.glassline.com

METAL PRODUCTS

GENERAL



Niles Aluminum Products, Inc. **NGA**
 Niles Aluminum Products
 1434 S. 9th St.
 P.O. Box 607
 Niles, MI 49120-0607
 Phone: 269/683-1191
 Fax: 269/683-8664
 E-mail:
 jeff@nilesaluminum.com
 www.nilesaluminum.com

ALUMINUM EXTRUSIONS



Oldcastle BuildingEnvelope **ADV NGA**
 More Than 85 Manufacturing and Distribution Locations in 25 US States, 4 Canadian Provinces, 3 Australian States.
 US: 866-OLDCASTLE (653-2278)
 www.obe.com

ALUMINUM EXTRUSIONS: BULLET RESISTANT



RIOT GLASS **ADV**
 Riot Glass LLC
 17941 Brookshire Ln.
 Huntington Beach, CA 92647
 US: 800/580-2303
 Phone: 714/904-1030
 E-mail: brad@riotglass.com
 www.riotglass.com

BENDING EXTRUSIONS



Niles Aluminum Products, Inc. **NGA**
 Niles Aluminum Products
 1434 S. 9th St.
 P.O. Box 607
 Niles, MI 49120-0607
 Phone: 269/683-1191
 Fax: 269/683-8664
 E-mail:
 jeff@nilesaluminum.com
 www.nilesaluminum.com

METALS: ARCHITECTURAL



Niles Aluminum Products, Inc. **NGA**
 Niles Aluminum Products
 1434 S. 9th St.
 P.O. Box 607
 Niles, MI 49120-0607
 Phone: 269/683-1191
 Fax: 269/683-8664
 E-mail:
 jeff@nilesaluminum.com
 www.nilesaluminum.com

METALS: CURVING



Niles Aluminum Products, Inc. **NGA**
 Niles Aluminum Products
 1434 S. 9th St.
 P.O. Box 607
 Niles, MI 49120-0607
 Phone: 269/683-1191
 Fax: 269/683-8664
 E-mail:
 jeff@nilesaluminum.com
 www.nilesaluminum.com

MIRRORS & RELATED PRODUCTS

GENERAL



American Insulated Glass **ADV**
 7 Regional Fabrication Locations in the US
 US: 866/519-1565
 Phone: 404/361-9154
 E-mail: sales@aiglass.com
 Web: www.aiglass.com



Glassfab Tempering Services **ADV**
 1448 Mariani Ct.
 Tracy, CA 95304
 US: 800/490-3860
 Phone: 209/229-1060
 Fax: 209/229-1061
 E-mail: info@GlassfabUSA.com
 www.GlassfabUSA.com

ACID ETCHED

McGrory Glass Inc.
 1400 Grandview Ave.
 Paulsboro, NJ 08066
 Phone: 800/220-3749
 Fax: 856/579-3233
 E-mail: sales@mcgrory.com
 www.mcgrory.com

ANTIQUE



GGI **NGA ADV**
 101 Venture Way
 Secaucus, NJ 07094
 US: 800/431-2042
 Phone: 201/553-1850
 Fax: 201/553-1851
 E-mail: sales@generalglass.com
 www.generalglass.com

DETECTION/SAFETY & SECURITY

McGrory Glass Inc.
 1400 Grandview Ave.
 Paulsboro, NJ 08066
 Phone: 800/220-3749
 Fax: 856/579-3233
 E-mail: sales@mcgrory.com
 www.mcgrory.com

PROTECTIVE GUARDS & BARRIERS

GENERAL

Oldcastle BuildingEnvelope **ADV NGA**
 More Than 85 Manufacturing and Distribution Locations in 25 US States, 4 Canadian Provinces, 3 European Countries and 3 Australian States.
 US: 866-OLDCASTLE (653-2278)
 www.obe.com

POINT-OF-PURCHASE DIVIDERS: GLASS/ACRYLIC

Oldcastle BuildingEnvelope **ADV NGA**
 More Than 85 Manufacturing and Distribution Locations in 25 US States, 4 Canadian Provinces, 3 European Countries and 3 Australian States.
 US: 866-OLDCASTLE (653-2278)
 www.obe.com

SNEEZE GUARDS

Oldcastle BuildingEnvelope **ADV NGA**
 More Than 85 Manufacturing and Distribution Locations in 25 US States, 4 Canadian Provinces, 3 European Countries and 3 Australian States.
 US: 866-OLDCASTLE (653-2278)
 www.obe.com

TRANSACTION SYSTEMS

Oldcastle BuildingEnvelope **ADV NGA**
 More Than 85 Manufacturing and Distribution Locations in 25 US States, 4 Canadian Provinces, 3 European Countries and 3 Australian States.
 US: 866-OLDCASTLE (653-2278)
 www.obe.com

SEALANTS & ADHESIVES

SILICONE

C.R. Laurence Co. Inc. **ADV NGA**
 2503 E. Vernon Ave.
 Los Angeles, CA 90058
 US: 800/421-6144
 E-mail: crl@claurance.com
 www.claurance.com

CONSULTING



Sole Source Consultants
 Custom solutions for marketing and brand growth.
 E-mail: max@solesource.info
 www.solesourceconsultants.com

repurposed**MATERIALS**

WANTED: GLASS

... used, surplus or
obsolete inventories
of tempered and
insulated glass panels.

**Call Damon
303/321-1471**

repurposed**MATERIALS**

METAL BENDING



Niles Aluminum Products NGA
1434 S. 9th St.
P.O. Box 607
Niles, MI 49120-0607
Phone: 269/683-1191
Fax: 269/683-8664
E-mail:
jeff@nilesaluminum.com
www.nilesaluminum.com

RECYCLING

repurposed**MATERIALS**
13505 E. 112th Ave.
Brighton, CO 80603
US: 877/282-8733
Phone: 303/321-1471
E-mail: damon@
repurposedmaterialsinc.com
www.repurposedmaterialsinc.com
(See our ad on this page)

STAFFING NEEDS

HoLampCo International
5825 Ellsworth Ave.
Pittsburgh, PA 15232
US: 800/875-6268
Phone: 412/954-0000
Fax: 412/954-0030
E-mail: patti@hlcinternational.com/
gary@hlcinternational.com
www.holampcoresources.com
(See our ad on this page)



Our team of professional "headhunters"
has been dedicated to **servicing the talent**
in the façade world since 1982

Patti Lampl, Managing Partner

Patti@hlcinternational.com
(O) 412.954.0000 or
(C) 412.656.6904

Gary Holupka, PE, Managing Partner

Gary@hlcinternational.com
(O) 412.954.0000 or
(C) 412.656.6903

www.holampcoresources.com

We welcome your call.

TRAINING PROGRAMS



INTERLAYER SOLUTIONS
EVALAYER
EVA films and more
Interlayer Solutions Inc.
6440 Boul. Henri Bourassa E.
Montreal, QC H1G 5W9 Canada
US: 855/873-1404
Phone: 514/326-4003
Fax: 514/326-9982
E-mail:
info@interlayersolutions.com
www.interlayersolutions.com

WEB SERVICES

Mainstreet Computers Inc. ADV
330 Charles St.
Belleville, MI 48111
US: 800/698-6246
Phone: 734/699-0025
Fax: 734/697-8228
E-mail:
sales@mainstreetcomp.com
www.mainstreetcomp.com

SKYLIGHTS & OVERHEAD GLAZING

GENERAL



Glassfab Tempering Services ADV
1448 Mariani Ct.
Tracy, CA 95304
US: 800/490-3860
Phone: 209/229-1060
Fax: 209/229-1061
E-mail: info@GlassfabUSA.com
www.GlassfabUSA.com



Oldcastle BuildingEnvelope*
More Than 85 Manufacturing and
Distribution Locations in 25 US
States, 4 Canadian Provinces, 3
European Countries and 3
Australian States. ADV
NGA
US: 866-OLDCASTLE
(653-2278)
www.obe.com

ARCHITECTURAL

Crystal Structures/Sushine Rooms
3333 N. Mead St.
Wichita, KS 67219
Phone: 316/838-0033
E-mail: contactus@csglazing.net
www.crystalstructuresglazing.com

COMMERCIAL

Crystal Structures/Sushine Rooms
3333 N. Mead St.
Wichita, KS 67219
Phone: 316/838-0033
E-mail: contactus@csglazing.net
www.crystalstructuresglazing.com

Oldcastle BuildingEnvelope*
More Than 85 Manufacturing and
Distribution Locations in 25 US
States, 4 Canadian Provinces, 3
European Countries and 3
Australian States. ADV
NGA
US: 866-OLDCASTLE
(653-2278)
www.obe.com

CONSERVATORIES

Crystal Structures/Sushine Rooms
3333 N. Mead St.
Wichita, KS 67219
Phone: 316/838-0033
E-mail: contactus@csglazing.net
www.crystalstructuresglazing.com

CUSTOM

Crystal Structures/Sushine Rooms
3333 N. Mead St.
Wichita, KS 67219
Phone: 316/838-0033
E-mail: contactus@csglazing.net
www.crystalstructuresglazing.com

Oldcastle BuildingEnvelope*
More Than 85 Manufacturing and
Distribution Locations in 25 US
States, 4 Canadian Provinces, 3
European Countries and 3
Australian States. ADV
NGA
US: 866-OLDCASTLE
(653-2278)
www.obe.com

GREENHOUSES

Crystal Structures/Sushine Rooms
3333 N. Mead St.
Wichita, KS 67219
Phone: 316/838-0033
E-mail: contactus@csglazing.net
www.crystalstructuresglazing.com

POOL ENCLOSURES

Crystal Structures/Sushine Rooms
3333 N. Mead St.
Wichita, KS 67219
Phone: 316/838-0033
E-mail: contactus@csglazing.net
www.crystalstructuresglazing.com

SLOPED GLAZING SYSTEMS

Crystal Structures/Sushine Rooms
3333 N. Mead St.
Wichita, KS 67219
Phone: 316/838-0033
E-mail: contactus@csglazing.net
www.crystalstructuresglazing.com

Oldcastle BuildingEnvelope*
More Than 85 Manufacturing and
Distribution Locations in 25 US
States, 4 Canadian Provinces, 3
European Countries and 3
Australian States. ADV
NGA
US: 866-OLDCASTLE
(653-2278)
www.obe.com

SOLAR GREENHOUSES

Crystal Structures/Sushine Rooms
3333 N. Mead St.
Wichita, KS 67219
Phone: 316/838-0033
E-mail: contactus@csglazing.net
www.crystalstructuresglazing.com

SUNROOMS

Crystal Structures/Sushine Rooms
3333 N. Mead St.
Wichita, KS 67219
Phone: 316/838-0033
E-mail: contactus@csglazing.net
www.crystalstructuresglazing.com

TRANSLUCENT WALL PANELS

Crystal Structures/Sushine Rooms
3333 N. Mead St.
Wichita, KS 67219
Phone: 316/838-0033
E-mail: contactus@csglazing.net
www.crystalstructuresglazing.com

SPECIALTY GLASS PRODUCTS

GENERAL



Glassopolis
We Put Glass Contractors First
Fast Quotes. Fast Delivery
Phone: 800/262-9600
Fax: 800/872-9601
E-mail: sales@glassopolis.com
www.glassopolis.com

WOOD STOVE REPLACEMENT



Glassopolis
We Put Glass Contractors First
Fast Quotes. Fast Delivery
Phone: 800/262-9600
Fax: 800/872-9601
E-mail: sales@glassopolis.com
www.glassopolis.com



Technical Glass Products NGA
8107 Bracken Place SE
Snoqualmie, WA 98065
Phone: 800/426-0279
Fax: 425/396-8300
E-mail: sales@fireglass.com
www.fireglass.com

STOREFRONTS & CURTAINWALLS

GENERAL



Glassfab Tempering Services ADV
1448 Mariani Ct.
Tracy, CA 95304
US: 800/490-3860
Phone: 209/229-1060
Fax: 209/229-1061
E-mail: info@GlassfabUSA.com
www.GlassfabUSA.com



Oldcastle BuildingEnvelope*
More Than 85 Manufacturing and
Distribution Locations in 25 US
States, 4 Canadian Provinces, 3
European Countries and 3
Australian States. ADV
NGA
US: 866-OLDCASTLE
(653-2278)
www.obe.com

CURTAINWALLS

Oldcastle BuildingEnvelope*
More Than 85 Manufacturing and
Distribution Locations in 25 US
States, 4 Canadian Provinces, 3
European Countries and 3
Australian States. ADV
NGA
US: 866-OLDCASTLE
(653-2278)
www.obe.com



SAFTI FIRST™ Fire Rated Glazing ADV
100 N. Hill Dr., Ste. 12
Brisbane, CA 94005-1010
US: 888/653-3333
Phone: 415/824-4900
Fax: 415/824-5900
E-mail: info@safti.com
www.safti.com



Technical Glass Products NGA
8107 Bracken Place SE
Snoqualmie, WA 98065
Phone: 800/426-0279
Fax: 425/396-8300
E-mail: sales@fireglass.com
www.fireglass.com

CURTAINWALLS: UNITIZED

Oldcastle BuildingEnvelope*
More Than 85 Manufacturing and
Distribution Locations in 25 US
States, 4 Canadian Provinces, 3
European Countries and 3
Australian States. ADV
NGA
US: 866-OLDCASTLE
(653-2278)
www.obe.com

ENTRANCES: CUSTOM

REBCO Inc.
1171-1225 Madison Ave.
Paterson, NJ 07509-2248
US: 800/777-0787
Phone: 973/684-0200
Fax: 973/684-0118
E-mail: sales@REBCOinc.com
www.REBCOinc.com
(See our ad on page 84)

SECURITY GLAZING

Oldcastle BuildingEnvelope*
More Than 85 Manufacturing and
Distribution Locations in 25 US
States, 4 Canadian Provinces, 3
European Countries and 3
Australian States. ADV
NGA
US: 866-OLDCASTLE
(653-2278)
www.obe.com

Suppliers Guide

STOREFRONTS & ENTRANCES



Frameless Hardware Company **NGA ADV**
4361 Firestone Blvd.
South Gate, CA 90280
US: 888/295-4531
Phone: 323/968-2031
Fax: 323/336-8307
E-mail: info@fhc-usa.com
www.fhc-usa.com

McGrory Glass Inc.
1400 Grandview Ave.
Paulsboro, NJ 08066
Phone: 800/220-3749
Fax: 856/579-3233
E-mail: sales@mcgrory.com
www.mcgrory.com



SAFTI FIRST™ Fire Rated Glazing **ADV NGA**
100 N. Hill Dr., Ste. 12
Brisbane, CA 94005-1010
US: 888/653-3333
Phone: 415/824-4900
Fax: 415/824-5900
E-mail: info@safti.com
www.safti.com

Oldcastle BuildingEnvelope®
More Than 85 Manufacturing and Distribution Locations in 25 US States, 4 Canadian Provinces, 3 European Countries and 3 Australian States. **ADV NGA**
US: 866-OLDCASTLE (653-2278)
www.obe.com



Technical Glass Products **NGA**
8107 Bracken Place SE
Snoqualmie, WA 98065
Phone: 800/426-0279
Fax: 425/396-8300
E-mail: sales@fireglass.com
www.fireglass.com

STOREFRONTS & ENTRANCES: SECURITY

McGrory Glass Inc.
1400 Grandview Ave.
Paulsboro, NJ 08066
Phone: 800/220-3749
Fax: 856/579-3233
E-mail: sales@mcgrory.com
www.mcgrory.com



Riot Glass LLC **ADV**
17941 Brookshire Ln.
Huntington Beach, CA 92647
US: 800/580-2303
Phone: 714/904-1030
E-mail: brad@riotglass.com
www.riotglass.com

THERMAL BREAK STRUT

Frameless Hardware Company **NGA ADV**
4361 Firestone Blvd.
South Gate, CA 90280
US: 888/295-4531
Phone: 323/968-2031
Fax: 323/336-8307
E-mail: info@fhc-usa.com
www.fhc-usa.com

WINDOW HARDWARE & RELATED PRODUCTS

GENERAL

Strybuc Industries **NGA**
2006 Elmwood Ave. 
Building 102-C
Sharon Hill, PA 19079-0767
US (PA): 800/352-0800
US (FL): 800/780-5051
Fax: 610/534-3202
E-mail: cservice@strybuc.com
www.strybuc.com

SCREENS & COMPONENTS



Frameless Hardware Company **NGA ADV**
4361 Firestone Blvd.
South Gate, CA 90280
US: 888/295-4531
Phone: 323/968-2031
Fax: 323/336-8307
E-mail: info@fhc-usa.com
www.fhc-usa.com

WINDOWS

GENERAL



Oldcastle BuildingEnvelope®
More Than 85 Manufacturing and Distribution Locations in 25 US States, 4 Canadian Provinces, 3 European Countries and 3 Australian States. **ADV NGA**
US: 866-OLDCASTLE (653-2278)
www.obe.com

ALUMINUM

Liberty Glass & Metal Industries
339 Riverside Dr.
N. Grosvenordale, CT 06255
Phone: 800/843-2031
Fax: 860/923-9662
E-mail: info@lgm.net
www.lgminc.net
(See our ad on page 91)

Oldcastle BuildingEnvelope®
More Than 85 Manufacturing and Distribution Locations in 25 US States, 4 Canadian Provinces, 3 European Countries and 3 Australian States. **ADV NGA**
US: 866-OLDCASTLE (653-2278)
www.obe.com

ARCHITECTURAL

Oldcastle BuildingEnvelope®
More Than 85 Manufacturing and Distribution Locations in 25 US States, 4 Canadian Provinces, 3 European Countries and 3 Australian States. **ADV NGA**
US: 866-OLDCASTLE (653-2278)
www.obe.com

BLAST RESISTANT

Oldcastle BuildingEnvelope®
More Than 85 Manufacturing and Distribution Locations in 25 US States, 4 Canadian Provinces, 3 European Countries and 3 Australian States. **ADV NGA**
US: 866-OLDCASTLE (653-2278)
www.obe.com

SAFTI FIRST™ Fire Rated Glazing **ADV NGA**
100 N. Hill Dr., Ste. 12
Brisbane, CA 94005-1010
US: 888/653-3333
Phone: 415/824-4900
Fax: 415/824-5900
E-mail: info@safti.com
www.safti.com

Vetrotech Saint-Gobain Fire-Rated Glass and Framing **ADV NGA**
2108 B St. NW, Ste. 110
Auburn, WA 98001
Phone: 888/803-9533
E-mail: vetrotech.sales@saint-gobain.com
www.vetrotechusa.com

BULLET RESISTANT



McGrory Glass Inc.
1400 Grandview Ave.
Paulsboro, NJ 08066
Phone: 800/220-3749
Fax: 856/579-3233
E-mail: sales@mcgrory.com
www.mcgrory.com



RAY-BAR USA **NGA**
Security, Ballistic Glass and IGU's 
US: 800/444-9729
Fax: 800/333-9729
E-mail: sales@raybar.com
www.raybar.com



Riot Glass LLC **ADV**
17941 Brookshire Ln.
Huntington Beach, CA 92647
US: 800/580-2303
Phone: 714/904-1030
E-mail: brad@riotglass.com
www.riotglass.com

SAFTI FIRST™ Fire Rated Glazing **ADV NGA**
100 N. Hill Dr., Ste. 12
Brisbane, CA 94005-1010
US: 888/653-3333
Phone: 415/824-4900
Fax: 415/824-5900
E-mail: info@safti.com
www.safti.com

Vetrotech Saint-Gobain Fire-Rated Glass and Framing **ADV NGA**
2108 B St. NW, Ste. 110
Auburn, WA 98001
Phone: 888/803-9533
E-mail: vetrotech.sales@saint-gobain.com
www.vetrotechusa.com

DOUBLE HUNG

Oldcastle BuildingEnvelope®
More Than 85 Manufacturing and Distribution Locations in 25 US States, 4 Canadian Provinces, 3 European Countries and 3 Australian States. **ADV NGA**
US: 866-OLDCASTLE (653-2278)
www.obe.com

FIRE-RATED



McGrory Glass Inc.
1400 Grandview Ave.
Paulsboro, NJ 08066
Phone: 800/220-3749
Fax: 856/579-3233
E-mail: sales@mcgrory.com
www.mcgrory.com



RAY-BAR USA **NGA**
Fastest Fire Glass and IGU's Available 
Phone: 800/444-9729
Fax: 800/333-9729
E-mail: sales@raybar.com
www.FireProofGlass.com



SAFTI FIRST™ Fire Rated Glazing **ADV NGA**
100 N. Hill Dr., Ste. 12
Brisbane, CA 94005-1010
US: 888/653-3333
Phone: 415/824-4900
Fax: 415/824-5900
E-mail: info@safti.com
www.safti.com



Technical Glass Products **NGA**
8107 Bracken Place SE
Snoqualmie, WA 98065
Phone: 800/426-0279
Fax: 425/396-8300
E-mail: sales@fireglass.com
www.fireglass.com

Vetrotech Saint-Gobain Fire-Rated Glass and Framing **ADV NGA**
2108 B St. NW, Ste. 110
Auburn, WA 98001
Phone: 888/803-9533
E-mail: vetrotech.sales@saint-gobain.com
www.vetrotechusa.com

FIXED

Oldcastle BuildingEnvelope®
More Than 85 Manufacturing and Distribution Locations in 25 US States, 4 Canadian Provinces, 3 European Countries and 3 Australian States. **ADV NGA**
US: 866-OLDCASTLE (653-2278)
www.obe.com

HURRICANE RESISTANT

Oldcastle BuildingEnvelope®
More Than 85 Manufacturing and Distribution Locations in 25 US States, 4 Canadian Provinces, 3 European Countries and 3 Australian States. **ADV NGA**
US: 866-OLDCASTLE (653-2278)
www.obe.com

SAFTI FIRST™ Fire Rated Glazing **ADV NGA**
100 N. Hill Dr., Ste. 12
Brisbane, CA 94005-1010
US: 888/653-3333
Phone: 415/824-4900
Fax: 415/824-5900
E-mail: info@safti.com
www.safti.com

Vetrotech Saint-Gobain Fire-Rated Glass and Framing **ADV NGA**
2108 B St. NW, Ste. 110
Auburn, WA 98001
Phone: 888/803-9533
E-mail: vetrotech.sales@saint-gobain.com
www.vetrotechusa.com

IMPACT RESISTANT

McGrory Glass Inc.
1400 Grandview Ave.
Paulsboro, NJ 08066
Phone: 800/220-3749
Fax: 856/579-3233
E-mail: sales@mcgrory.com
www.mcgrory.com



RAY-BAR USA **NGA**
Fastest X-Ray Glass and IGU's Available 
US: 800/444-XRAY
Fax: 800/333-XRAY
E-mail: sales@raybar.com
www.raybar.com



Technical Glass Products **NGA**
8107 Bracken Place SE
Snoqualmie, WA 98065
Phone: 800/426-0279
Fax: 425/396-8300
E-mail: sales@fireglass.com
www.fireglass.com

LEAD X-RAY

Amerope Enterprises Inc. **NGA**
150 Commerce Rd.
Boynton Beach, FL 33426
US: 800/327-3320
Phone: 561/737-7370
Fax: 561/737-3721
E-mail: claire@amerope.com
www.amerope.com



McGrory Glass Inc.
1400 Grandview Ave.
Paulsboro, NJ 08066
Phone: 800/220-3749
Fax: 856/579-3233
E-mail: sales@mcgrory.com
www.mcgrory.com

RAY BAR

RAY-BAR USA
Fastest X-Ray Glass
and IGU's Available
US: 800/444-XRAY
Fax: 800/333-XRAY
E-mail: sales@raybar.com
www.raybar.com



NUCLEAR SHIELDING

Amerope Enterprises Inc.
150 Commerce Rd.
Boynton Beach, FL 33426
US: 800/327-3320
Phone: 561/737-7370
Fax: 561/737-3721
E-mail: claire@amerope.com
www.amerope.com



McGrory Glass Inc.
1400 Grandview Ave.
Paulsboro, NJ 08066
Phone: 800/220-3749
Fax: 856/579-3233
E-mail: sales@mcgrory.com
www.mcgrory.com

SECONDARY GLAZING



Riot Glass LLC
17941 Brookshire Ln.
Huntington Beach, CA 92647
US: 800/580-2303
Phone: 714/904-1030
E-mail: brad@riotglass.com
www.riotglass.com



SECURITY

McGrory Glass Inc.
1400 Grandview Ave.
Paulsboro, NJ 08066
Phone: 800/220-3749
Fax: 856/579-3233
E-mail: sales@mcgrory.com
www.mcgrory.com

RAY BAR

RAY-BAR USA
Security, Ballistic Glass
and IGU's
US: 800/444-9729
Fax: 800/333-9729
E-mail: sales@raybar.com
www.raybar.com



Technical Glass Products
8107 Bracken Place SE
Snoqualmie, WA 98065
Phone: 800/426-0279
Fax: 425/396-8300
E-mail: sales@fireglass.com
www.fireglass.com



SINGLE HUNG

Oldcastle BuildingEnvelope®
More Than 85 Manufacturing and
Distribution Locations in 25 US
States, 4 Canadian Provinces, 3
European Countries and 3
Australian States.
US: 866-OLDCASTLE
(653-2278)
www.obe.com



SPECIALTY

Oldcastle BuildingEnvelope®
More Than 85 Manufacturing and
Distribution Locations in 25 US
States, 4 Canadian Provinces, 3
European Countries and 3
Australian States.
US: 866-OLDCASTLE
(653-2278)
www.obe.com



THERMAL BREAK

Oldcastle BuildingEnvelope®
More Than 85 Manufacturing and
Distribution Locations in 25 US
States, 4 Canadian Provinces, 3
European Countries and 3
Australian States.
US: 866-OLDCASTLE
(653-2278)
www.obe.com



SAFTI FIRST™ Fire Rated Glazing
100 N. Hill Dr., Ste. 12
Brisbane, CA 94005-1010
US: 888/653-3333
Phone: 415/824-4900
Fax: 415/824-5900
E-mail: info@safti.com
www.safti.com



Liberty Glass & Metal Industries

Toll free: 800-843-2031
estimating@lgmnc.net
www.lgmnc.net



2" Projected Window Systems Specifically Designed for Commercial Applications



Commercial Rated Windows

Vetrotech Saint-Gobain Fire-Rated Glass and Framing
2108 B St. NW, Ste. 110
Auburn, WA 98001
Phone: 888/803-9533
E-mail:
vetrotech.sales@saint-gobain.com
www.vetrotechusa.com



Glass Magazine Employment Center

Job title, keyword...



Advanced Search

The Source for Glass & Glazing Professionals

- Find the right opportunities faster @ jobs.glassmagazine.com
- Free resume posting with confidential options
- Set criteria for your ideal position

Reader Response Center

Advertiser	Page	Phone	Website or email address
A+W Software	67		a-w.com/us
Azon	25	800/788-5942	azonintl.com
Bottero Glass Technologies	35		bottero.com
Burkle	44		burkle.tech/us-en/
C.R. Laurence	9	800/421-6144	crlaurence.com
Curved Glass Distributors	81	888/288-9129	curvedglasscreations.com
Deceuninck	1		innergy-ap.com
Dow	33		dow.com/advanced-engineering
Erdman Automation	2	763/389-9475	erdmanautomation.com
Ergo Robotic Solutions	21, 85	518/796-2179	ergorobotic.com
FeneTech Inc.	19	330/995-2830	fenetech.com
Frameless Hardware Co.	61	888/295-4531	fhc-usa.com
GDS Estimating	82	858/538-4375	gdsestimating.com
GED	17	440/600-8605	gedusa.com
GGI	29, 43A	800/431-2042	generalglass.com
Glass Magazine Employment Center	91		jobs.glassmagazine.com
GlassBuild America	95	703/442/4890 ext.142	glassbuild.com
Glassfab Tempering Services	5	800/490-3860	glassfabusa.com
Glasshape North America	36	206/272-0602	email: andrew@glasshape.com
Glasswerks	71	888/789-7810	glasswerks.com
GuangDong Kin Long Hardware Products	22		email: mail@kinlong.com
Guardian Glass	55		guardianglass.com
Hegla Corp.	77	404/763-9700	email: info@heglaus.com
HHH Equipment Resources	7	724/212-3749	hhhglassequipment.com
HoLampCo International	89	800/875-6268	holampcoresources.com
JLM Wholesale	18	704/509-2940	jlmwholesale.com
Jordon Glass Machinery	87	800/833-2159	jordonglass.com
Joseph Machine Company	42	717/432-3442	josephmachine.com
Kuraray America Inc.	31		email: trosifol@kuraray.com
Lattuada NA	47	567/249-4486	email: info@lattuada-na.com
Liberty Glass & Metal Industries	91	800/843-2031	lgminc.net
MarketPro Point of Sale Solutions	82	888/616-3706	marketpropos.com
McKeegan Equipment & Supply	86	734/459-5870	mckeeganequip.com
Mueller Technologies AG	88	905/427-3400	muller.ch
MyGlassTruck	24	800/254-3643	myglasstruck.com
NGA's GANA Glazing Manual	93	703/442/4890 ext. 127	glass.org/store
Precision Glass Bending Corp.	28, 81	800/543-8796	e-bentglass.com
REBCO	84	800/777-0787	REBCOinc.com
repurposedMATERIALS	89	303/321-1471	repurposedmaterialsinc.com
Riot Glass	23	800/580-2303	riotglass.com/b2b-signup/
Rockwell Security	80	510/270-5633	rockwellsecurityinc.com
Seclock	13	800/847-5625	seclock.com
SGC International Inc.	79	866/802-8682	sgc-usa.com
Smart Glazier Software	37		smartglazier.com/fabricators
US Horizon Mfg.	24	877/728-3874	ushorizon.com
Vetrotech Saint-Gobain	32	888/803-9533	vetrotech.com
Viprotron	41	313/384-3855	email: ric.schmidt@viprotron.com
Viracon	3		viracon.com
Vitro Architectural Glass	96		starphireglass.com
Xinyi Glass & Mirror North America	27		email: sales@xygglass.com
Yorglass	14-15		yorglass.com

The definitive resource in the glass and glazing field

**NGA MEMBERS
SAVE!**

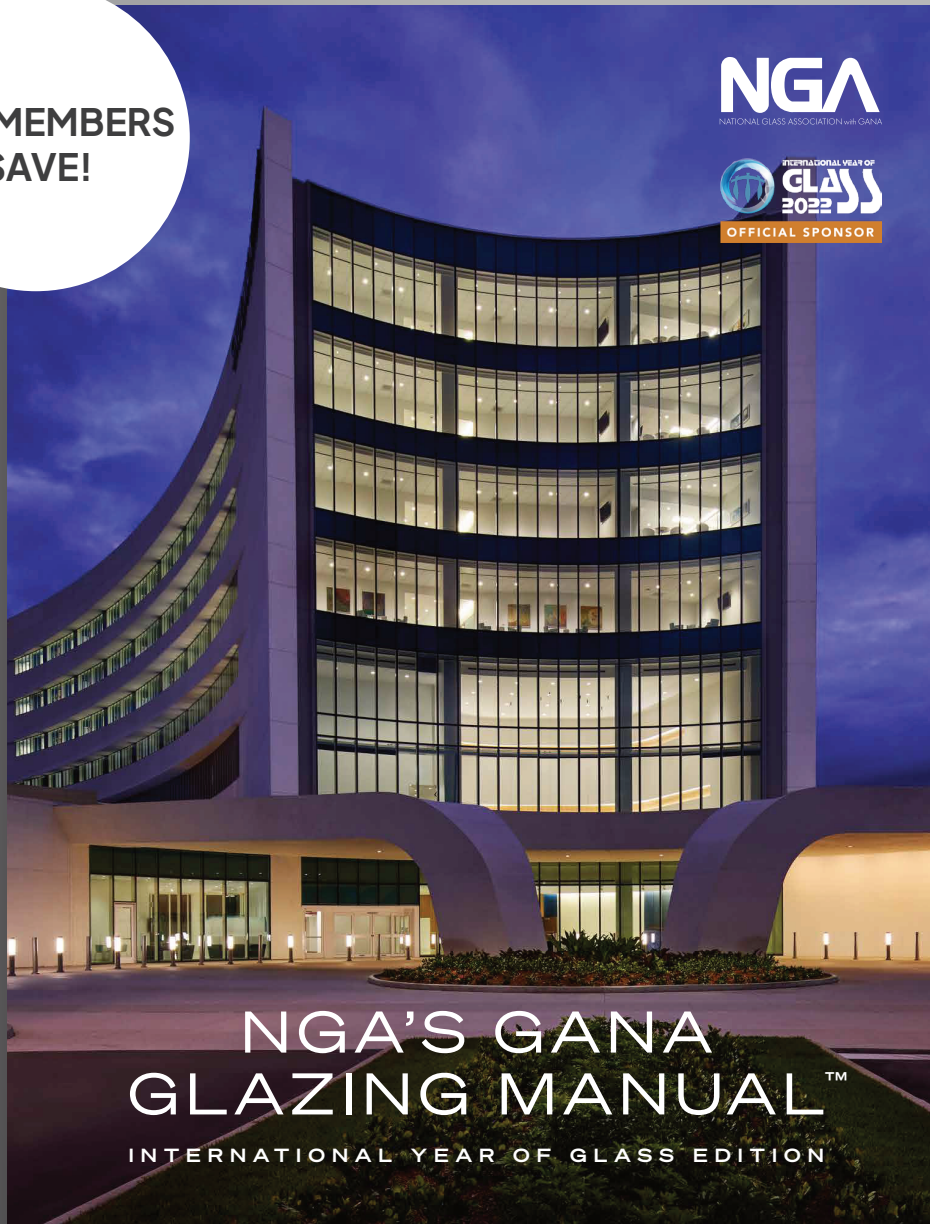

UPDATED IN 2023! With complete information about primary and fabricated glass products, quality standards, general and specific glazing guidelines & more.

Order your copy today at glass.org/store.



Companies from all parts of the glass and glazing industry have implemented innovative, out-of-the-box ideas to improve business from the ground up. Here's an Idea showcases these sometimes small behind-the-scenes ideas that can make a big impact on a company's bottom line. If you have an idea that you would like to share, contact *Norah Dick*, ndick@glass.org.



REPURPOSING UNWANTED GLASS

Left: A designer for an apartment complex in California changed the specifications for the shower doors at the last minute, after they had already been shipped. This is a rendering of the shower doors. **Right:** The rain-pattern shower glass was repurposed for a “She Shed” residential structure.

Repurposed Materials Inc. calls itself an “industrial thrift store,” according to Founder and President Damon Carson. The company finds new homes for the “cast-offs and discards of American industry,” including glass. They have six warehouses across the U.S. that are about a one-day truck drive from anywhere in the country, give or take.

Without a national glass recycling infrastructure, the company offers an opportunity to reuse and repurpose architectural glass.

How it works

Companies call Repurposed Materials and let them know what materials they have that are not needed or wanted. Sometimes businesses or people replace the old glass or order the wrong sizes and cannot return them, but they want to keep the glass out of a landfill. Repurposed Materials picks it up and then stores it in a warehouse until someone else, whether an individual or another company, calls them or

checks their website to see if they have a particular material available.

One example is an Apple store in Palo Alto, California, which had 7-by-30-foot glass atrium skylights that were being replaced with new ones. Apple’s subcontractors contacted Repurposed Materials to keep this glass out of a landfill. Repurposed Materials then brought four semi-trucks to Palo Alto, picked up the crates of glass and brought them to their Arizona warehouse.

Those 14 pieces of glass were rehomed over three months. Ten pieces went to someone in Washington building a large sustainable home, and the other four went to an organic winery in North Carolina.

How it's helping

“One of the questions we often hear is, ‘Does repurposing make more sense environmentally or economically?’ For companies like Apple, it makes sense environmentally because we’re helping

them divert their unwanted materials from the landfill,” says Carson. “For our customer base, it makes economic sense; they typically save 50% to 75% over buying that same product or material new.”

Hopes moving forward

“We would love to help more glass manufacturers, distributors, glaziers and architects because it is interesting to me that within the U.S. glass industry there’s a lot of unwanted glass that comes in for all kinds of different reasons,” says Carson.

“‘It doesn’t fit this project,’ ‘it was a half-inch too long,’ ‘it’s a half-inch too short,’ ‘they want this tempering now instead of this tempering’—these are some of the reasons people need to rehome glass,” says Carson. “Then there are six crates of glass that don’t fit the new specifications. In that situation, we could be a resource over time to the industry.” ■

2023

OCT 31 - NOV 2

Georgia World
Congress Center
ATLANTA, GA



20 YEARS
OF GLASSBUILD

GlassBuild AMERICA

THE GLASS, WINDOW & DOOR EXPO

BIGGER BUSINESS HAPPENS AT GLASSBUILD.

STAY AHEAD OF THE INDUSTRY, CODES, TRENDS,
AND YOUR COMPETITION AT GLASSBUILD AMERICA.



THE TRADITION CONTINUES

Join the rest of the industry and see why more glaziers, fabricators, window & door manufacturers, dealers and suppliers reunite at GlassBuild America—more than any other conference, trade show or expo in the Western Hemisphere—for the buying/selling, education, networking, and supply chain solutions they need to grow and thrive.

THE BIGGEST GLASS & FENESTRATION EVENT OF THE YEAR

MORE EXHIBITORS
MORE ATTENDEES
MORE OPPORTUNITIES



PRESENTED BY



WITH ASSOCIATION SPONSOR



GLASSBUILD.COM

INFINITE POSSIBILITIES

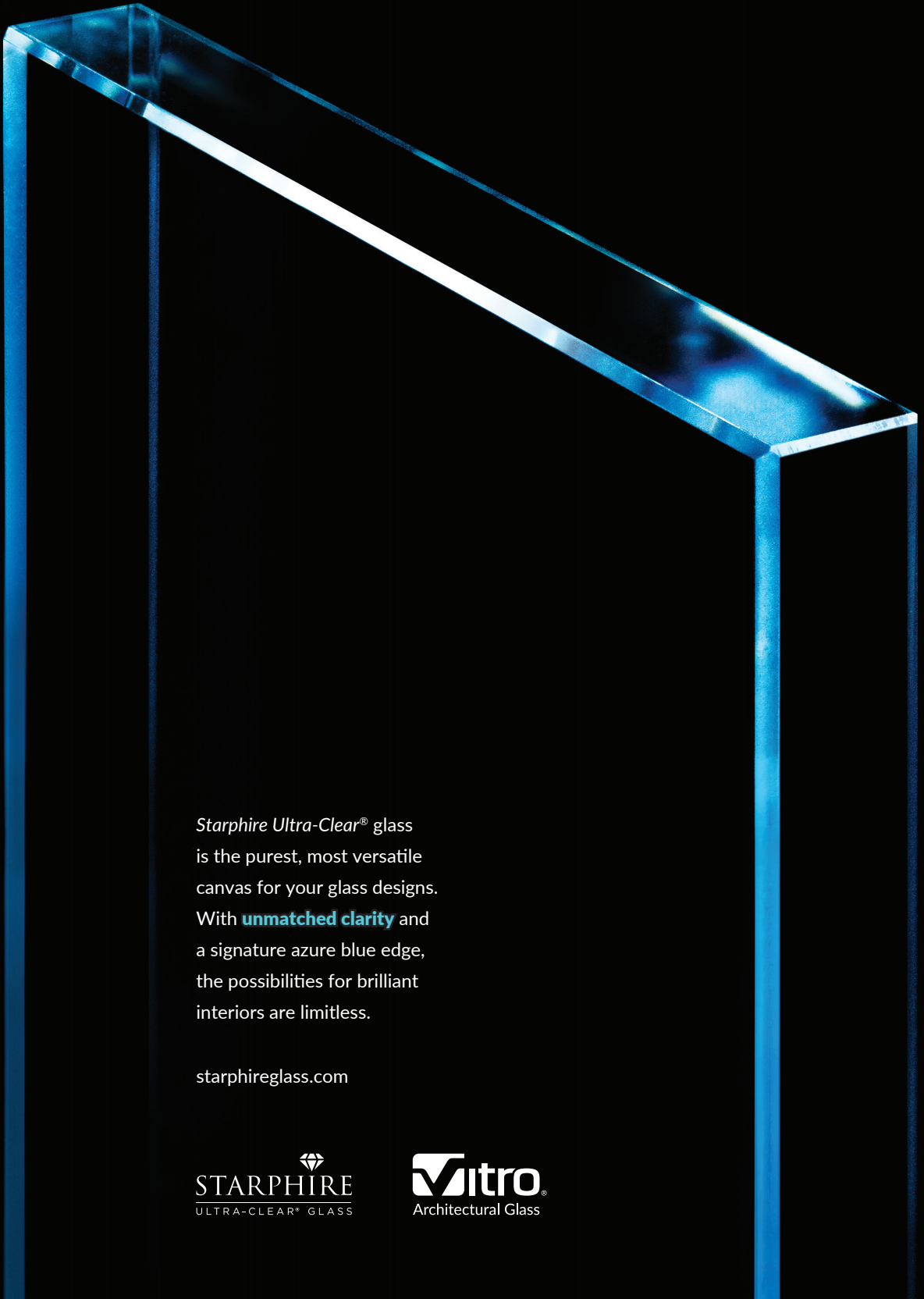

Starphire Ultra-Clear® glass
is the purest, most versatile
canvas for your glass designs.
With **unmatched clarity** and
a signature azure blue edge,
the possibilities for brilliant
interiors are limitless.

starphireglass.com

STARPHIRE
ULTRA-CLEAR® GLASS

Vitro®
Architectural Glass